



**Adam Tas Corridor Energy**

# **100kWh remote power supply for backbone network use**





## 100kWh remote power supply for backbone network use

---



### 100 kWh Battery Energy Storage System Solution

Pknergy 100 kWh Battery Energy Storage System Technical Solution In the current energy landscape, companies face the twin challenges of growing energy costs

### Planning & Engineering Guidelines for Remote Line Power Networks

Deployment of Remote Line Power networks changes some of the practices and processes for planning and engineering. The copper cables that typically supplied -48Vdc power for POTS now deliver

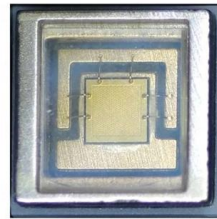

### CTECHI 100KW 215KWH 230KWH 241KWH Commercial & Industrial BESS Solar

The system includes a 105KW power conversion system (PCS) with a maximum efficiency of 98.5%. It supports wide voltage ranges on both

### JM 100kwh High-Density LiFePO4 Battery with Smart BMS for All

JM 100kwh High-Density LiFePO4 Battery with Smart BMS for All-Terrain Remote Worksite



Power Supply, Find Details and Price about 100kwh Battery High-Density Battery from JM 100kwh High

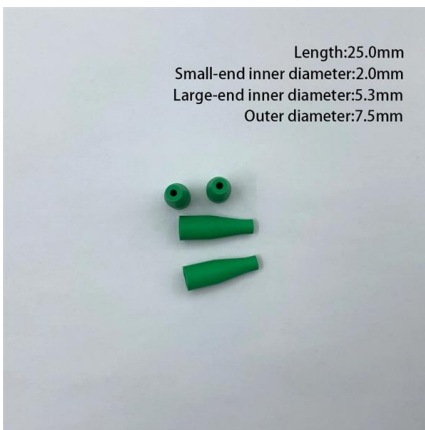

## How to Select Solar Panels & Batteries for 100kWh Load

Learn how to size solar panels and batteries to run a 100kWh load 24/7, including peak sun hour analysis, backup planning, seasonal impact, and

## 60kWh 100kwh LiFePO4 Battery Pack Reliable Solar

Products This high-performance LiFePO4 (Lithium Iron Phosphate) battery pack is available in 60kWh and 100kWh capacities, designed for medium to large-scale



## High Voltage 100kWh Solar Battery Storage System for

Designed to support residential properties, this 100 kWh home battery offers exceptional performance for large homes and energy-intensive applications. With



## Mobile LiFePO4 Battery 100kWh Storage System for Construction

Designed for off-grid power supply, portable battery storage, and EV fast charging applications, this system enables reliable and seamless charging in construction sites, events, emergency backup



## EnergyPack: The Ultimate 100kWh Battery Solution for Remote and

Whether for mining operations, telecommunications, or rural electrification, the EnergyPack P100 optimizes energy use through intelligent peak shaving and load management, significantly cutting

## 100kWh 512V 205Ah Commercial Solar Battery Storage

The EGbatt 100kwh battery pack stands as EGbatt's conventional offering for microgrid applications, along with commercial and industrial energy storage



## Electric power transmission

Electric power transmission is the bulk movement of electrical energy from a generating site, such as a power plant, to an electrical substation. A long



### **KRL-B100 50kW/100kWh All-in-One BESS , KRL Power Factory**

Whether establishing independent micro-grids with its oversized 100kW MPPT solar input for remote mountainous areas and islands, or maximizing the efficiency of large-scale PV power generation, our

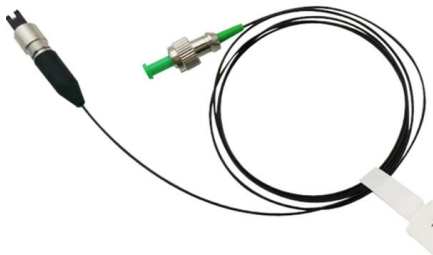

### **EnergyPack P100: The Reliable 100kWh Battery Storage Solution for**

The EnergyPack P100 is a state-of-the-art 100 kWh battery storage system developed by Foxtheon for use in outlying or remote areas. This advanced energy storage system is ideal for

### **Mobile 100kWh Power Box 30kW DC Fast Charging Events Use Off**

Designed for off-grid power supply, portable battery storage, and EV fast charging applications, this system enables reliable and seamless charging in construction sites, events, emergency backup





## Emergency Energy Storage Power Supply 100kWh: Reliable

In an era of climate extremes and grid instability, 100kWh emergency energy storage systems have emerged as critical infrastructure for industries, renewable energy projects, and commercial facilities.

## Off-Grid Solar Power for Remote Telecom Towers , Anern

Discover comprehensive insights into powering telecom towers and remote base stations with off-grid solar and energy storage solutions. Explore

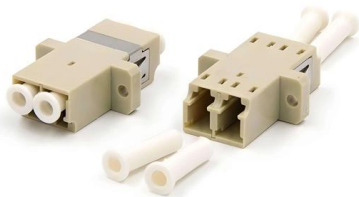

## Uninterrupted remote site power supply

Uninterrupted power supply for remote base stations has been a challenge since the founding of the wireless industry, but alternative sources have a chance of

## 100KWH Battery Pack High Voltage Power

The 112s1p configuration 100kWh battery pack is built for projects where reliability and voltage stability aren't optional. Whether embedded in a containerized ESS or installed in a power cabinet, this pack



### **Portable 100kWh Power Solution 30kW DC Fast Charge Temporary Power**

Designed for off-grid power supply, portable battery storage, and EV fast charging applications, this system enables reliable and seamless charging in construction sites, events, emergency backup



### **50KW Complete House Use Full 100KWH Solar Energy System Solar**

Hybrid Inverters · Programmable working mode ·  
Quadruple capacity by paralleling 4 units · One  
inverter fails in parallel system · Supports remote  
control of DG · Uninterruptable power supply  
guaranteed ·

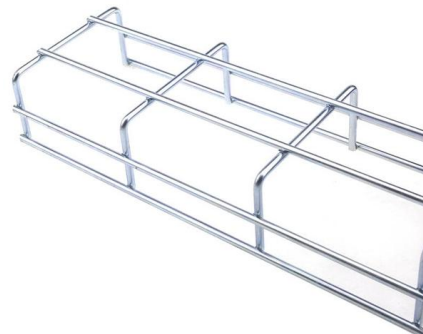

### **Remote Power Panels and Busways Help Data Centre Teams**

Data centre and IT teams also have another  
choice: standardised remote power panels. This  
solution is easy to order, install and service and  
can be flexibly placed in spaces ranging from  
server rooms and

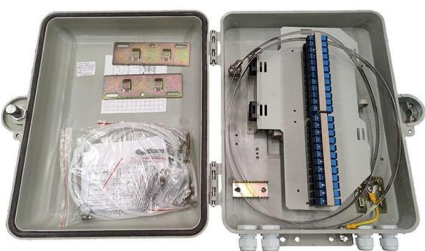



## Emergency Energy Storage Power Supply 100kWh: Reliable

Why 100kWh Emergency Power Storage Is Reshaping Energy Resilience In an era of climate extremes and grid instability, 100kWh emergency energy storage systems have emerged as critical



## Advanced Remote Area Power Supply Solutions: Reliable,

Discover innovative power supply solutions for remote locations featuring advanced energy management, hybrid power integration, and modular scalability. Ensure reliable, sustainable power

## How to Choose the Best 100kWh Battery Energy Storage System:

Learn what to look for in a 100kWh battery energy storage system, from key specs to safety and value. Make an informed decision with this expert buying guide.



## Mobile LiFePO4 Battery 100kWh Storage System for Construction

MOBILE EV CHARGING : Delivering high-performance power for electric vehicles without the need for permanent charging infrastructure. Designed for flexible deployment in remote areas, events,

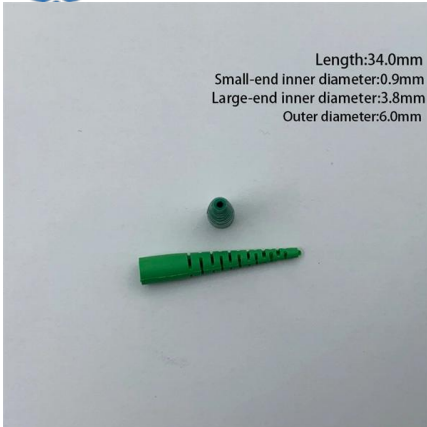

## 100KW High Voltage Energy Power System Lithium Battery

Our 100kW-115kW High Voltage Lithium Battery Energy Power System is the ultimate solution for commercial solar power applications. Designed to



## Insights , Siemens

Explore how we're bringing AI to the real world through digital twins, autonomous infrastructure and software-defined automation.

## Can I use powerstation (capacity 100kwh) to provide power supply to

Can I use powerstation (capacity 100kwh) to provide power supply to my wifi router (30w/12v)? And if yes then Maintain Your LFP Portable Power Station for a Longer Lifespan without damage lithium





## Remote Power Supply

Marlec are Experts in providing Renewable Solutions for Remote Power Supply to Professional Applications Wherever there is a need for low

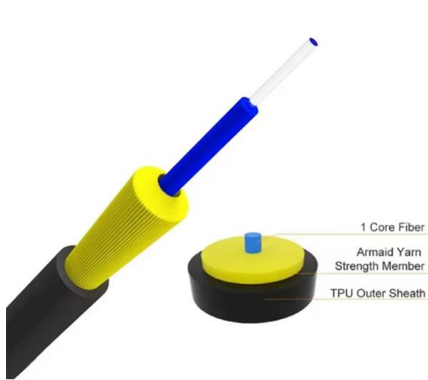

## Contact Us

---

For datasheets, pricing, or custom telecom energy solutions, please visit:  
<https://koskolong.co.za>