



Adam Tas Corridor Energy

ASEAN Enclosed Fireproof Cable Tray





ASEAN Enclosed Fireproof Cable Tray



FIRE RESISTANT SYSTEMS

Since its founding, EAE has grown rapidly, expanding its production and areas of operation by incorporating EAE Lighting in 1983, EAE Machinery in 1996, EAE Electrotechnics in 2004, and EAE

Fire-Resistant Cable Trays , Cable Tray Manufacturers in UAE , West

Cable tray manufacturers in UAE and cable tray suppliers in Dubai provide fire-resistant trays and cable tray accessories that ensure safety, durability, and compliance.



Cable Tray Covering & Fire Protection

Build fire-rated enclosures around tray runs, transitions, and penetrations to block flame and smoke movement. Integrate coverings with existing fireproofing and firestopping systems for full compliance

Fire protection for cables & cable trays , Flamro

Fire protection solutions to protect cables, cable trays and cable systems. Discover our tested



cable coatings and fire protection bandages!



Fireproof Trough-Type (Enclosed) Cable Tray

Fireproof Trough-Type (Enclosed) Cable Tray
High Protection Rating: Completely isolates dust, moisture, oil contamination, and external mechanical damage, providing the most comprehensive



Enclosed Cable Tray

NewReach Enclosed Cable Tray provides you with enhanced protection against dust, moisture, corrosion, fire, and other external factors. Designed for durability,

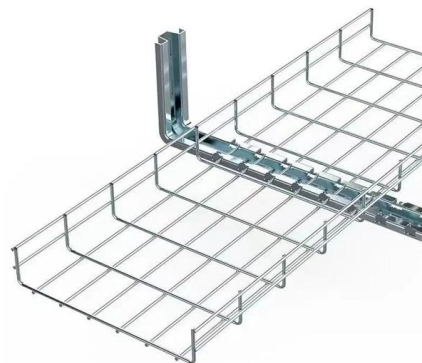

High Quality Fully Enclosed Cable Tray Galvanized

Fireproof cable tray adopts steel shell, double-layer fireproof cover plate, inorganic fireproof slot box inside, double-layer cover plate ventilation and heat dissipation,





Fire-resistant cable tray

Find out all of the information about the NIEDAX product: fire-resistant cable tray . Contact a supplier or the parent company directly to get a quote or to find out a



Slot-type fireproof cable tray

The fully enclosed design provides protection against dust, rodent bites, and mechanical damage, while reducing electromagnetic interference. It is suitable for various cable laying scenarios,

DAKEN Fire-resistant Cable Tray

This innovative design not only provides excellent fire resistance, but also effectively addresses the common issues associated with traditional fully enclosed cable trunking systems, such as heat



Verified Supplier Enclosed Cable Tray Fireproof & Easy Installation

An enclosed cable tray is a protective system used to support and organize electrical cables in commercial, industrial, and infrastructure environments. Unlike open tray systems, enclosed trays



Fire Rated Cable Tray, Heavy-Duty Cable Tray Manufacturer

Fire Rated Cable Trays that are crafted from premium materials like stainless steel, galvanized steel, tempered glass, and fire-resistant polyester fiberglass. Each tray is coated with a specialized fire

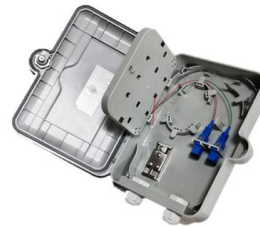

Fire-Resistant Cable Trays , Cable Tray Manufacturers in UAE , West

Solutions from cable tray manufacturers in UAE and reliable cable tray suppliers in Dubai are playing an increasingly important role in this direction. Fire-Resistant Materials and Construction Such trays are



Technical Guidelines for Cable Tray Installation and

1. Route Planning and Layout Principles
Coordinate with Building Structure: Cable tray routing should align with architectural design, avoiding unnecessary

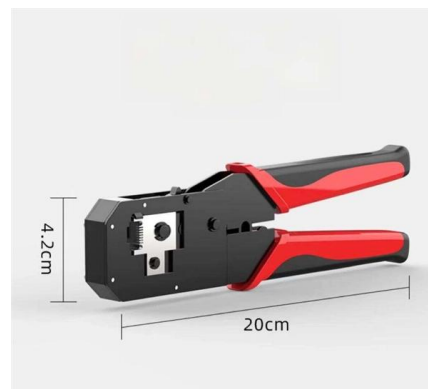



Advanced Fire Resistant Cable Tray , Maximum Heat

Top-quality fire resistant cable tray with N1 fire rating, 5-12 mm fireproof core, superior heat insulation, flame protection, and 60-min fire resistance.

Metal Cable Tray & Fireproof Cable Tray from China Factory , ecer

Buy quality Metal Cable Tray and Fireproof Cable Tray, Langfang Dongkuo Electrical Equipment Co., Ltd - Manufacturer of Perforated Cable Tray from China

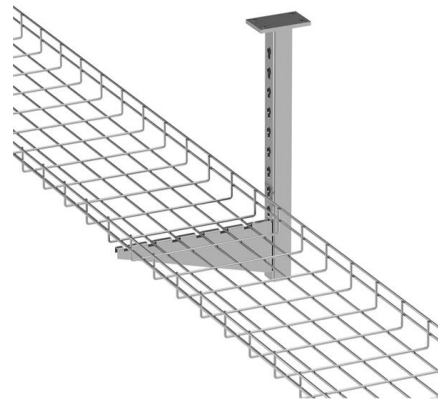

Why Choose Fireproof Cable Trays for Safety?

Fireproof cable trays can be employed in a wide range of applications, including commercial buildings, hospitals, data centers, and even residential setups where fire safety is a

Fire-Resistant Cable Trays , Trafalgar Fire Products

Discover Trafalgar Fire's fire-resistant cable trays. Ensure safety and compliance with our top-quality fire protection solutions for cable management.





Sealed Fireproof Cable Tray

Our Sealed Fireproof Cable Tray excels in delivering exceptional quality and reliability for fire protection. Designed with the B2B purchaser in mind, these trays offer durable solutions that meet rigorous

Enclosed Cable Tray Suppliers And Factories In China

Also, enclosed cable trays are divided with firm bottom formations, ideal for public areas and most visited places like hospitals, schools, and retail markets.

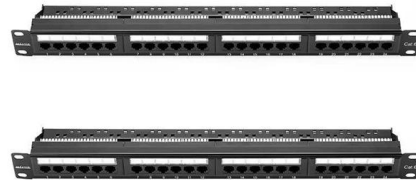

Fire-Resistant Cable Trays in High-Risk Environments

Explore the importance of fire-resistant cable trays in high-risk environments. Learn about the best materials and practices to

Basor Electric

Basor Electric, sensitive to the need to minimize the consequences of a fire, has subjected its cable trays to rigorous fire resistance tests to ensure the behavior of



Trunking and Cable Tray Protection

Fire prevention is a critical aspect of safeguarding both residential and commercial buildings. One of the essential components in this arena is the protection of



Fire Rated Cable Encasements: Invicta Durasteel

Our 4-hour fire rated cable encasements provide comprehensive fire and blast protection, shielding cables from fire and containing high voltage cable fires



Contact Us

For datasheets, pricing, or custom telecom energy solutions, please visit:
<https://koskolong.co.za>