

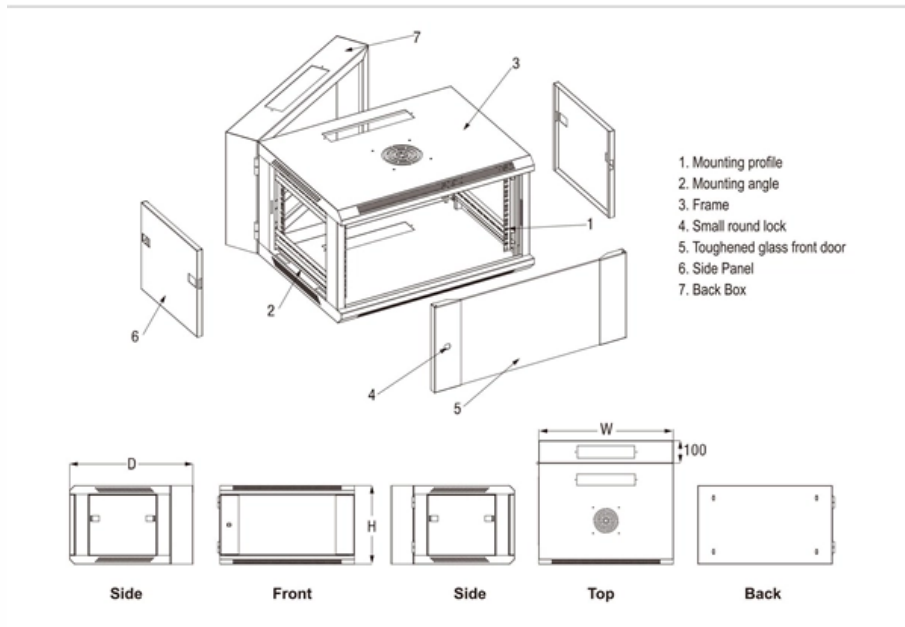

# Brief News on Cleaning Distribution Boxes





## Overview

---

Malé, Maldives – STELCO has officially commenced cleaning and maintaining its distribution boxes in various streets of Malé as part of its new initiative, "Clean Environment - My Responsibility." **Prev : For Stainless Steel Distribution Boxes, Weather Resistance Is Crucial In Outdoor Environments.** Key warning signs include unusual noises (buzzing or humming), burning smells, visible damage to components, frequent circuit breaker trips, or warm spots on the enclosure. Use a soft cloth or sponge with a mild detergent mixed in water to wipe away dirt, oil, and stains. Avoid abrasive chemicals or rough scrubbers that could damage the surface finish or labeling.



## Brief News on Cleaning Distribution Boxes

---



### Essential Insights and Tips for Septic System Distribution Boxes

Discover key insights and maintenance tips for septic system distribution boxes to ensure optimal performance and longevity.

### 8 Crucial Steps for Cleaning Switchgear (with Key)

In 2019, a major data center in New Jersey experienced a sudden regional power outage, knocking out 1,200 servers and resulting in over \$2 million



### How To Clean a Litter Box Step by Step

Keeping a litter box clean is an important part of caring for your cat. Here's how to clean a litter box, from everyday maintenance to deep cleaning.

### Comprehensive Guide on Septic System Distribution

Explore a comprehensive guide on septic system distribution boxes, covering design, installation,



maintenance, and troubleshooting.



## Notable Cleaning Distribution Stories from 2024

News & Views 12/26/2024 Notable Cleaning Distribution Stories from 2024 A variety of pressing topics defined the cleaning distribution industry in 2024.

## Container cleaning

Cleaning, de-oiling, degreasing - resource-saving and environmentally friendly. The sprintBOX is your ideal partner for container cleaning.



## 8 Crucial Steps for Cleaning Switchgear (with Key

Prevent costly outages! Learn 8 crucial steps for effective switchgear cleaning & maintenance, including safety tips & industrial standards. Essential



## How Distribution Boxes Work in Septic Systems

In this video, we're exploring the distribution box in a septic system. We'll cover its various shapes and sizes, the function of the PVC cleanout observation port, and how the inlet and drain



## Maintenance Tips for Your Distribution Box

Your distribution box, the electrical system's core in your home, efficiently distributes power to various circuits. Regular maintenance is vital to

## Behälterreinigung

Mit sprintBOX erhalten Sie erstklassige Behälterreinigung & KLT-Reinigung für höchste Ansprüche. Unser Fokus liegt auf Effizienz und kurzen Reinigungszeiten,



## Clogged Septic Distribution Box? 7 Things Only a Septic Professional

A clogged septic tank distribution box (also known as a D-box) is a serious issue that can affect the performance and safety of an entire septic system. When this critical component becomes blocked,



### **Low Voltage Distribution Boxes maintenance and care**

Regularly inspect Low Voltage Distribution Boxes every three months to catch problems early and avoid costly repairs. Always clean the boxes using safe methods. Turn off power, use dry



### **Cleaning Tips For Daily Maintenance Of Stainless Steel**

In the operation and maintenance management of power facilities, the cleaning work of waterproof stainless steel enclosure is often overlooked. Long-term

### **Low Voltage Distribution Boxes maintenance and care**

Maintain Low Voltage Distribution Boxes with regular inspection, cleaning, and preventive care to ensure safety, reliability, and longer service life.





## **A Brief History of the Seattle Weekly Distribution Box**

A Brief History of the Seattle Weekly Distribution Box From dirty diapers to Girl Scout cookies to quality journalism, you never know what you'll find.

## **Distribution Centre Cleaning: Challenges & Solutions 2026**

Discover common distribution centre cleaning challenges and expert solutions to keep your warehouse safe, hygienic, and efficient year-round.



## **What are the common problems of distribution boxes?**

The main problems encountered with distribution boxes include installation and layout problems, electrical connection and grounding problems,

## **Imperial Dade , Food Packaging Supplies , Commercial**

Imperial Dade is the leading independently owned and operated distributor of food packaging supplies, commercial cleaning supplies, paper products, commercial



## How to Clean Out a Septic Distribution Box

Comprehensive guide for locating, safely cleaning, and adjusting the flow within your septic system's distribution box.

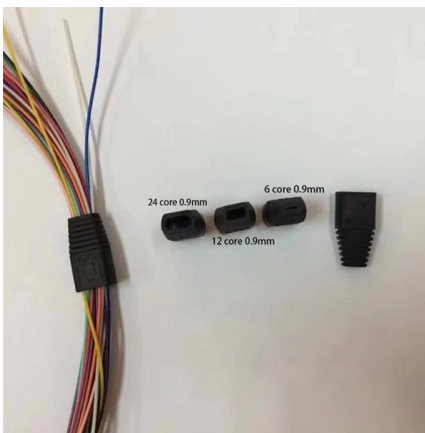

## On the cleaning requirements of distribution box

Cleaning the distribution box can reduce the cost of operation and maintenance, and also reduce the inconvenience of power failure to users. After the operator completes the power failure operation of



## Electrical Enclosure Cleaning & Maintenance: Best

A clean electrical enclosure means safer operations, fewer failures, and longer equipment life. Whether you're managing a single control box or a full





## Regular maintenance checklist: ensuring safe and reliable operation of

If you're responsible for maintaining electrical systems, you know that distribution boxes are the unsung heroes of power management. These metal workhorses silently direct electricity

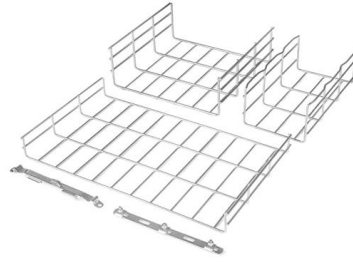

## Comprehensive Guide to Septic Tank Distribution Box Issues

Explore common problems with septic tank distribution boxes, their symptoms, solutions, and maintenance tips for homeowners.

## Comprehensive Guide to Clogged Septic Distribution Boxes

Explore essential insights on clogged septic distribution boxes, including causes, signs, prevention, and effective solutions.



## Distribution Board Maintenance: Tips to Ensure span and Efficiency

Distribution boards, also known as electrical panels or breaker boxes, play a crucial role in distributing electricity safely and efficiently throughout a building. To ensure the longevity and



## MCB Distribution Box Maintenance Tips for Electricians

For electricians and maintenance professionals, understanding proper MCB distribution box maintenance is essential. This guide outlines practical, field



## Maintenance Tips for Long-Lasting Distribution Boxes

As a central component that manages power flow throughout a facility, a well-maintained distribution box ensures safety, efficiency, and uninterrupted operations. Understanding how to

## How to Replace a Septic Distribution Box

The distribution box of the septic tank system is used to evenly distribute the wastewater from the septic system to the dispersal field. Over time,





## **STELCO Launches "Clean Environment"**

Malé, Maldives - STELCO has officially commenced cleaning and maintaining its distribution boxes in various streets of Malé as part of its new

## **Contact Us**

---

For datasheets, pricing, or custom telecom energy solutions, please visit:  
<https://koskolong.co.za>