



Adam Tas Corridor Energy

Canadian Complete Distribution Box Inspection Technology





Canadian Complete Distribution Box Inspection Technology



Packaging Technologies And Inspection , Package Leak

PTI are leaders in packaging technologies and inspection that develop package integrity testing standards and offer entire solution for package inspection

ClearVision Technologies, Inc.

As a business of Valco Melton, one of the leading global manufacturers of adhesive dispensing systems and electronic monitoring equipment, ClearVision is specifically focused on box, case and

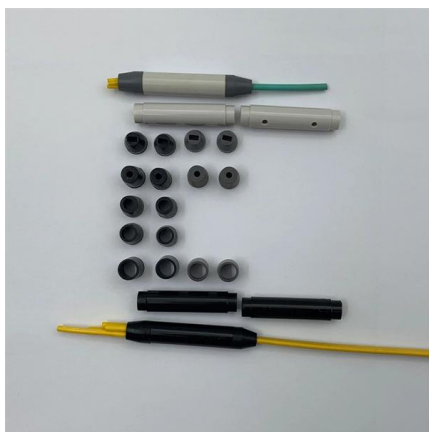

Inspection, Quality Systems & Integration

We are a full service product inspection company, with coverage across Canada, from metal detectors and Xray systems to artificial intelligence image processing. CPG Automation provides you with the

ZEISS ScanBox , Optical 3D Measuring & Inspection

Robotic 3D Scanning cells come as an all-in-one solution for plan programming, rapid



digitalization, and automated inspection and reporting. Learn more about

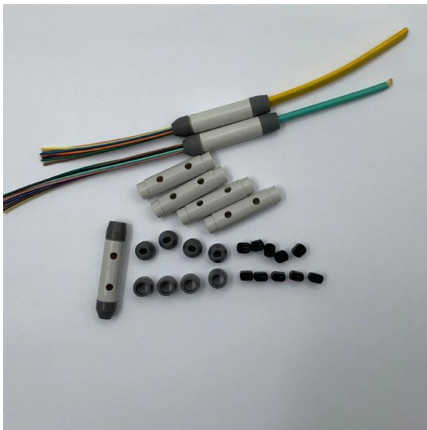

Packaging Integrity & Inspection , Cognex

Modern lines run at high speeds with diverse materials, creating complex inspection challenges. Reflective plastic wrap, transparent containers, and variable product arrangements all introduce

Distribution Box Manufacturing Process , Custom

At E-abel, we combine advanced production equipment, strict quality control, and international certification standards to provide high-performance distribution



Customization of a complete distribution box

Learn the step-by-step process of customizing complete distribution boxes tailored to your needs. From requirement confirmation to design,



Know Your Truck and Inspection Rules: A Guide for

Learn essential truck and inspection rules every Canadian truck driver must follow to stay compliant, safe, and avoid costly penalties on the road.



AUTOMATED PACKAGING AND INSPECTION SOLUTIONS SINCE

Our product inspection systems provide you with the performance and service you need to improve the quality and safety of your products, help you eliminate errors and ensure the integrity of your brand.

Way Down Under

Dynamic's knowledge of the dairy sector is unparalleled. Having integrated Fortress metal detector technology from its inception, the Dynamic Inspection team is already equipped with a



Digital Vehicle Inspections: A Guide for Canadian Shops

In this guide, you'll see why every Canadian auto shop should consider getting set up to do them. How Does a Digital Vehicle Inspection Work? To perform a DVI, your service rep first opens a work-order,



Business Standard

Hier sollte eine Beschreibung angezeigt werden, diese Seite lässt dies jedoch nicht zu.



Machine Vision for Box Inspection

The Box Inspection system is a machine vision system that inspects the packed boxes for damages, incorrect closing, etc.

SAFE TO RECLAIM T

case full of product is put through an Eagle X-Ray inspection system to find and remove small metal objects that may have found their way into the finished packages contained inside the corrugated





Special Inspections: SPE-1000 Certification for Canada

Next day Special Inspection, SPE-1000 Certification services for Electrical Equipment in Canada with fast turnaround times and reduced travel costs.

ClearVision Inspection Systems for Corrugated Boxes , Valco Melton

Vision Inspection & Quality Assurance In addition to providing enhanced glue pattern inspection (GlueChek(TM)), our inspection systems also offer specific packages for other box making



Way Down Under

Despite its corporate name, there is not a hint of so-called fortress mentality at the Toronto-based Fortress Technology Inc., a leading Canadian manufacturer of high-performance

How to Guarantee Rigid Box Quality? The Crucial Role

By understanding the multifaceted nature of rigid box inspection - from manual expertise to automated technologies, and the holistic quality control



Using Computer Vision to Inspect Incoming Boxes for

Intel sets out to replace an arduous and time-consuming manual process for inspecting damaged boxes in the warehouse, with an automated



How Product Inspection Technologies Help Co-Packers Prepare for

Advanced product inspection technologies generally make it possible for product setup and job changeover to be automated, saving valuable time, and ensuring that parameters for each



IRIDIS - Vision - Automated quality control

Whether it's a simple inspection or the most sophisticated solution for serialization of the packaging line, the determining factor is to have an exceptional optical configuration and vision algorithm.





ClearVision Inspection Systems for Corrugated Boxes , Valco Melton

Ensure flawless corrugated box quality with ClearVision camera systems. Detect imperfections, enhance production consistency, and reduce waste.



Canadian Roadside Inspections: Province-by-Province

This comprehensive province-by-province guide equips commercial drivers with essential knowledge to navigate roadside inspections across

Technology Tools Supporting Better Inspections and audits in

Final Thoughts As distribution centers become more complex and regulatory oversight intensifies, inspections and audits must be supported by technology--not held back by manual

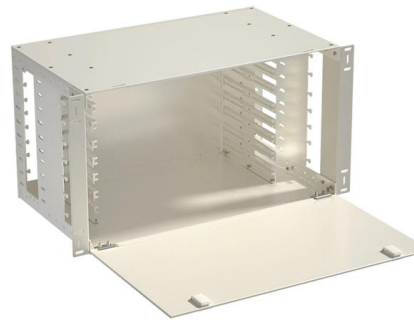

Content and Package Quality Inspection

Vision inspection solutions are able to perform complete dimensional and cosmetic inspections on package shape and closures as well as carry out full label inspection. Systems are infinitely scalable



Accessible Automation for Point Solutions in Distribution

Accessible Automation Point Solutions Technology advances in automated distribution have enabled a more integrated approach for the operation of material-handling systems, which, in



HOME , Canadian Inspection

We provide visual and NDT inspection services to various projects at different stages as per national and international codes and standards and provide final approval and issue letter of compliance.

Loma Systems to Unveil Cutting-Edge Metal-Detection, X-Ray-Inspection

The user-friendly touchscreen interface, complete with intuitive icon-driven menus, makes setup quick and easy. Additionally, with ingress ratings of up to IP69K, these detectors are ideal for

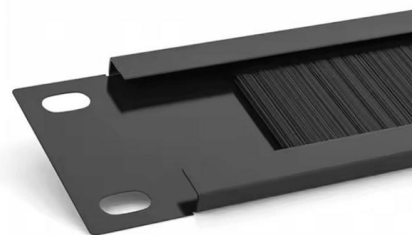



Contact Us

For datasheets, pricing, or custom telecom energy solutions, please visit:
<https://koskolong.co.za>