

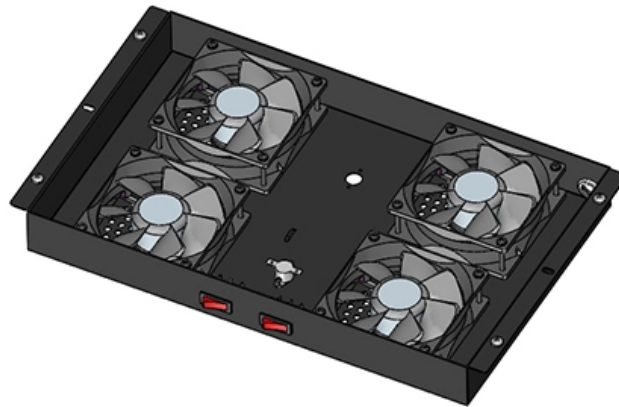

Adam Tas Corridor Energy

Concept of Relay Protection Override





Overview

This chapter focuses on the basics of power system relaying with special attention paid to the overcurrent, impedance, and differential protection. The MERIT software for those examples is a set of SIMULINK models in which: A single-phase model of a simple power system is developed using the Power System Blockset. If the current level increases more than the threshold value, after predefined time d . The load and fault conditions must be analyzed in order to select the CTs and CBs as well as to set the relays. The fault locations that need to be considered are those producing the minimum and maximum fault currents for each.



Concept of Relay Protection Override

4 essential implementations of protective relays in power



2. Transmission line protection Transmission lines can be protected by several types of relays, however the most common practice to protect

Working of an Override Control

Introduction The override control concept is a technique by which process variables are kept within certain limits, usually for protective purposes.



Basic Principles of Relay Protection

The primary principle of relay protection is based on the concept of detecting abnormal electrical conditions, known as faults, and initiating

Over Current Relay and Its Characteristics

Over Current Protection: It finds its application from the fact that in the event of fault the



current will increase to a value several times greater than



8-Port PLC Fiber Splitter Box
12-Port SC Fiber Splitter Box

Size: 235*215*75mm
Material: ABS, IP65,



Fundamental overcurrent, distance and differential

Important principles of fundamental relay protections: overcurrent, directional overcurrent, distance and differential relay protections.

Override Control Functions , Instrumentation Tools

Override control involves a selection between two or more controller output signals, where only one controller at a time gets the control over a process.

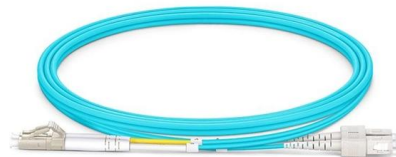

Relay Coordination Essentials

Get started with relay coordination in power systems engineering, covering the essential concepts, techniques, and best practices for a robust grid.



Protective Relaying Principles and Applications

The article provides an overview of protective relaying principles and their applications for high-voltage power system components.



Protective Relay: Working, Types, and Applications

Learn about protective relays, their working principle, types, and applications in power systems. Discover how relays protect transformers,

Fundamentals of Modern Protective Relaying

A primary motor protective element of the motor protection relay is the thermal overload element and this is accomplished through motor thermal image modeling. This model must account for thermal



What to Know About Protective Relays , EC& M

Protective relays are arguably the least understood component of medium voltage (MV) circuit protection. In fact, some believe that MV circuit breakers operate by themselves, without direct



Motor Protection

However, in LT motors, above five protections are used differently. In some cases where the kW rating of LT motor is more (generally more than 75



7 Core Concepts on Relay Coordination Basics: A

The 'Whats' and 'Whys' of power system protection. An overview of power system protection with focus on relay coordination basics - principles and objectives.

Protective Relay Basics

Fundamental concepts and terminology will be taught using the electromechanical overcurrent relay as a foundation and then these concepts will be expanded to modern numerical relays.





Introduction to Protective Relaying , Electric Power



What are Protective Relays, or Protection Relays?
Protective relays are used in industrial power generation and supply systems to open and isolate branch

Distribution Automation Handbook

The concept is especially suited for busbar protection, but it can also be implemented for the protection of short outgoing and incoming feeders and the transformer MV-side.



Protective relay

Microprocessor-based solid-state digital protection relays now emulate the original devices, as well as providing types of protection and supervision impractical with

PMU-based relays_v2.dvi

28 Power System Protective Relaying: basic concepts, industrial-grade devices, and communication mechanisms This report provides a survey of protective relaying technology and its associated com



Basics of Protective Relaying and Design Principles

Perform power system simulations of selected faults and observe how a given protection principle (overcurrent, impedance, and differential) works. Set the relays for a given power system. Verify by



The basics of power system protection that every

Introduction to relay protection Protection is the branch of electric power engineering concerned with the principles of design and operation of

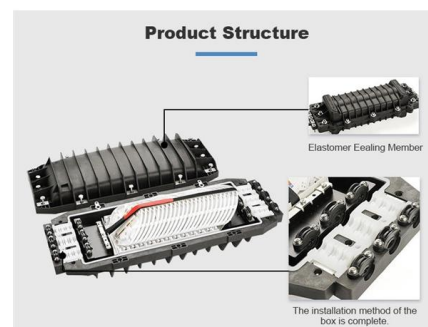

Distance protection relay with false tripping prevention

Distance protection relay with false tripping prevention Simulation of a distance protection relay connecting two grids with fault injection. Introduction A distance





Basic protection relay knowledge

Selectivity Selectivity is a mandatory requirement for all protection, but the importance of it depends on the application. For example, unselective protection operation during a medium voltage network fault

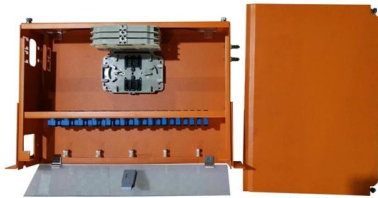

Fundamentals of Relay Protection Design

Relay protection is a crucial aspect of electrical power network transmission and distribution systems, ensuring the safety and reliability of the overall network. Designing an effective

How to use Lockout Relay (master trip relay) in

The concept of lockout relay as an intermediary of protection is illustrated in Figure 1. Initiation of fault signals in modern-day protection IED

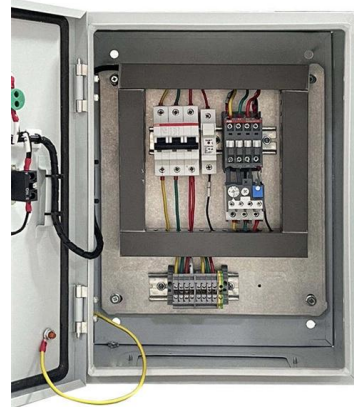

Basic protection relay knowledge

A fast and selective arc fault mitigation for air-insulated LV & MV switchgear and Relion protection and control relays and sensor technology protect staff and plant facilities for many years.



Understanding Protective Relays in Power Systems

Protective relays are vital for safeguarding power systems, ensuring protection against faults and abnormalities. This post explores key relay

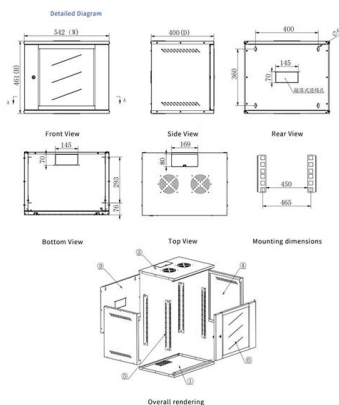

Basic Principles of Relay Protection

Relay protection is a vital aspect of electrical power systems that ensures the safety and integrity of the network, equipment, and personnel. It is

Voltage Protection Relay: Working Principle and Functions

A voltage protection relay is an essential device to keep electrical systems running efficiently and safely. These devices are designed to suit many unique situations.





Contact Us

For datasheets, pricing, or custom telecom energy solutions, please visit:
<https://koskolong.co.za>