



**Adam Tas Corridor Energy**

# **Dimensional Requirements for In-House Distribution Boxes**





## Overview

---

### What Is a Distribution Box?

A distribution box, also known as a power distribution unit, is a critical component in any electrical system.



## Dimensional Requirements for In-House Distribution Boxes

---

### A comprehensive understanding of distribution box

? Introduction Distribution boxes are at the heart of safe and organized electrical systems--whether in residential, commercial, or industrial settings. But

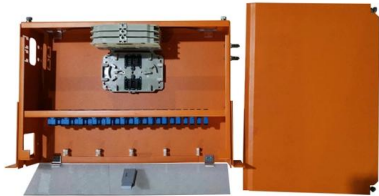

### 1.An Ultimate Guide for Metal Distribution Boxes

1) Metal Distribution Boxes Constructed from steel, aluminum, or cast iron, metal distribution boxes are highly durable and resistant to mechanical damage. Ideal



### Power Distribution Boxes Explained Simply

Discover the essentials of a Power Distribution Box--how it works, key types, benefits, and tips to ensure safe, efficient electrical power management.



### The Technical Specifications for Fiber Distribution Boxes

The fiber distribution box, a crucial component in optical fiber networks, serves a dual purpose of



managing and protecting optical fibers while facilitating



## Electrical Distribution Box Design Guide

The document provides details for designing the electrical distribution box and circuits for a residence. It includes specifications for the main circuit breaker such

## TECHNICAL SPECIFICATION FOR LT DISTRIBUTION BOX

General Technical Particulars for LT Distribution Boxes : - The L.T. Distribution Boxes should be of the dimensions as per the drawing & details in the table furnished.

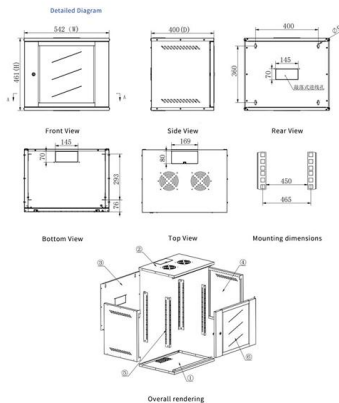

## Requirements And Specifications For Installation Of

The installation requirements and specifications of Distribution box involve many aspects, including site selection, fixing method, wiring specifications



## How to choose a distribution box of the right size for a project based

If you're like most electrical professionals, picking the right distribution box for your project can feel like navigating a maze. I've been in those shoes - staring at spec sheets, worrying about



### Distribution Box

Metal Distribution Box Features Continuously welded seams Foam-in-place seamless gasket 120-degree opening heavy-duty industrial hinges IP66 protection rating against dust and water according



## Complete Guide For Distribution Boxes Types

Distribution boxes, also known as electrical distribution boards or panels, are pivotal components in electrical systems, ensuring the safe and organized distribution of



### Distribution box , PDF

This document provides specifications for various types of plastic distribution boxes, including their dimensions and features. It describes HA, HK, and LGD series boxes with dimensions ranging from



## How to Choose a House Distribution Box , CHINT global

A well-chosen distribution box ensures the safety and efficiency of your household electrical system. This article guides you through selecting a



### Product Wiring Diagram

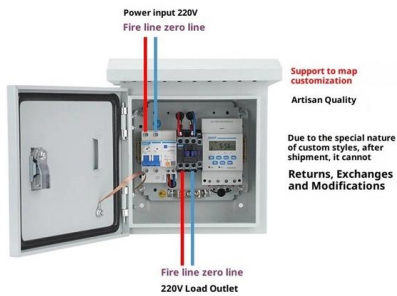

## Specific design requirements for distribution box.

The various indexes of the boards of distribution boxes or distribution cabinets must meet the relevant requirements of the state. All distribution boxes or distribution cabinets shall be made of cold-rolled

## Technical Requirements for Distribution Box in Electrical Industry

16. The distribution box system drawings are shown in the attached drawings. The above is the technical requirements of distribution box. On the premise of ensuring safety, the distribution box is still





## GENERAL REQUIREMENTS FOR CORRUGATED BOXES

1.0 SCOPE This document provides general material and functional requirements for corrugated boxes used for inbound, interplant, and outbound nonbulk shipments. The boxes described herein are

### How to Improve the Installation Quality of Distribution Boxes

The construction quality of distribution boxes directly impacts the overall quality level of a project. As the construction unit responsible for electrical equipment installation, it is essential to carry out the



### Comprehensive Guide to the Best Distribution Board Box: Technical

Choosing the right distribution board box can feel a bit overwhelming, but it really boils down to a few key technical details. First up, the material it's made from can make a big difference in

### Distribution Box and Selection Guide

This guide provides information on how to select the appropriate Distribution Box for Electric project. If you have any questions about distribution

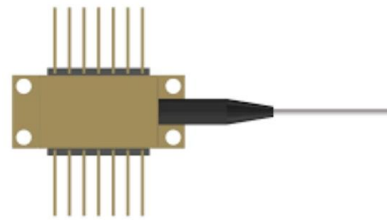

## How to Install a Cable Distribution Box Safely and

In modern electrical systems, cable distribution boxes (also known as electrical distribution boxes or distribution boxes) play a crucial role as the key



## Size determination, installation method and wiring mode

When the distribution box is installed on the wall, it shall be fixed with split bolts (expansion bolts). The bolt length is generally the sum of the buried depth (75 ~



## Customizing distribution boxes based on customer

Safety performance: The distribution box should have functions like overload protection, short circuit protection, and leakage protection to ensure

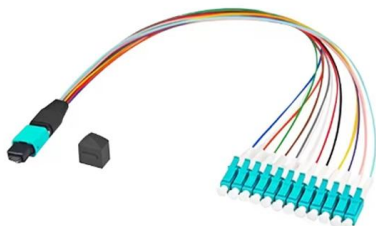



## Electrical Control Panels & Distribution Boxes: Sizes,

This guide explores control panels, electrical boxes, breaker panels, bus bars, junction boxes, and custom enclosures to help you understand their



## Distribution Boxes Explained: Types, Functions, and

Learn about distribution boxes, their types, functions, and safety features to ensure efficient and secure electrical power distribution in any building.

## Distribution Box and Selection Guide

The nature of your property plays a crucial role in determining the appropriate Distribution Box. Different settings have distinct electrical



## How to Choose the Right Distribution Box?

How to choose the right distribution box for a specific application is crucial for ensuring safe, efficient, and reliable power distribution. Different



## 12 types of distribution boxes and how to choose them

Key Factors in Choosing a Distribution Box  
Building Type and Size: Start with where it's going. For homes, a residential or flush-mounted box might suffice, but large spaces need sub-distribution



## Cautions and Requirements for Installation of

Distribution box is a low-voltage distribution device which assembles switchgear, measuring instruments, protective appliances and auxiliary equipment in a closed

## Contact Us

---

For datasheets, pricing, or custom telecom energy solutions, please visit:  
<https://koskolong.co.za>