



Adam Tas Corridor Energy

Energy-efficient optical network maintenance toolbox for mines





Energy-efficient optical network maintenance toolbox for mines

Application of Optical Communication for an Enhanced Health and

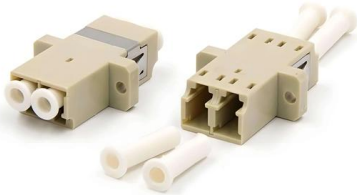

The communication system described here aims to allow data acquisition from underground and transmit them, in real time, to the mine surface, in order to monitor the methane

Energy Efficiency in Mining Operations: Policy and

Key innovations, including energy-efficient mining equipment, optimization algorithms, and renewable energy integration, are analyzed for their



Energy Efficiency in Optical Networks , Springer Nature Link

These aspects of energy-efficient optical network design are examined, along with issues related to mobile and optical network convergence, nonlinear optics and optical processing, and computer and



Design and Implementation of Solar-Powered Optical Fiber-Based

Silicate optical fibers of various core diameters and numerical apertures are characterized for



illumination applications and their efficiencies are reported. The possibility of achieving optical fiber-based

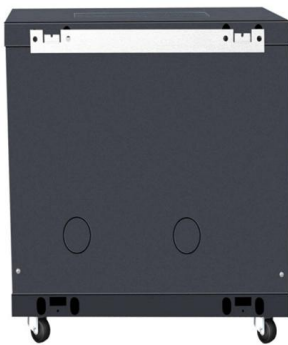

Optimizing Network Performance: Optical Network Unit Management

Effective management and maintenance of Optical Network Units (ONUs) are essential for network operators to ensure reliable and high-performance connectivity. By implementing

Technical Requirements of Intelligent Maintenance for Optical Network

It will specify basic functional requirements, interface requirements, reference architecture and requirements of intelligent maintenance for optical network, which is an important step as a start for



1Finity

1Finity (a part of Fujitsu) is a global company providing communication networks for our connected world. We uniquely combine technological leadership and



Optically powered gas monitoring system using single-mode fibre for

A 2-month field trial at BMA's Broadmeadow underground mine proved the cabling compatibility to the mine's existing optical network and the stability of the system performance.



Mining Fiber Solutions 2025: Dust, Moisture & Vibration

Mining fiber optic solutions in 2025 deliver robust resistance to dust, moisture, and vibration, essential for harsh mining environments. These solutions

Design of optical and wireless sensors for underground mining

Abstract Miner's health and safety is now considered as a major challenge, hence novel technologies such as optical sensors and wireless sensors networks (WSN) have been adopted to



Energy Efficiency in Next-generation Optical Networks

Abstract: Energy consumption in optical network infrastructures is investigated to identify energy-hungry key components and network functionalities. Solutions based on smart coherent pluggables are



Toward High-Capacity and Energy-Efficient Optical Networks

Indeed, DSCM permits to aggregate sub-carriers (thus traffic) all-optically, avoiding energy-hungry interfaces and electronic processing. In general, in optical networks, a relevant contribution to the



ABB launches digital portfolio ABB Ability(TM)

By ensuring that the right people have the right information at the right time and from anywhere, ABB Ability(TM) MineOptimize digital applications enable

(PDF) Energy Efficiency in Optical Networks

Energy Efficiency in Optical Networks October 2012 DOI: 10.1109/NETWORKS.2012.6381661 Conference: Networks 2012 - 15th International

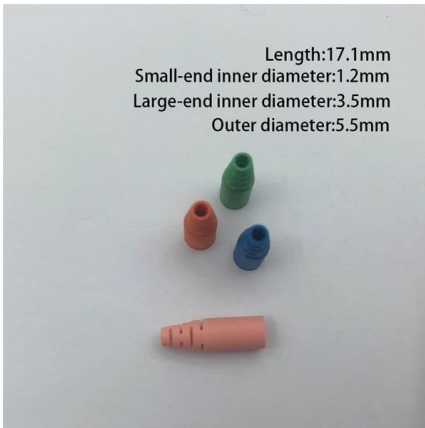
PRODUCT DETAILS

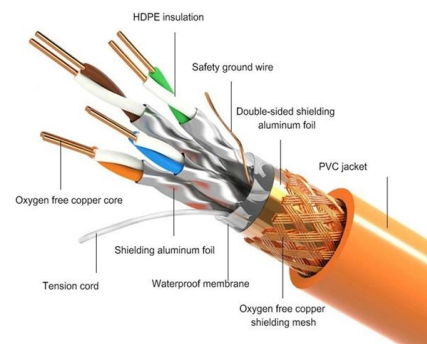



Energy efficient traffic data aggregation and routing for

The Energy Efficient Regional Area Metropolitan Optical Access Network (MOAN) is a modern optical communication system specifically

Technical Requirements of Intelligent Maintenance for Optical Network

This project addresses the benefit of introducing AI technology in optical network maintenance. It will specify basic functional requirements, interface requirements, reference architecture and



Energy-efficient network planning and traffic provisioning in IP-over

We judiciously use electrical and optical layer traffic grooming to reduce PC. We present a mixed integer linear programming (MILP) model and an auxiliary graph (AG)-based heuristic scheme

Optically powered gas monitoring system using single-mode fibre for

We address these shortcomings by proposing and developing an intrinsically safe optically powered gas monitoring network based on (1) power-over-fibre (PoF) at 1550 nm using a



Renewable energy-aware grooming in optical networks

The optical layer of a network is the energy-efficient technology to provision high bandwidths for data transport. Unfortunately, occasional electronic processing is unavoidable in

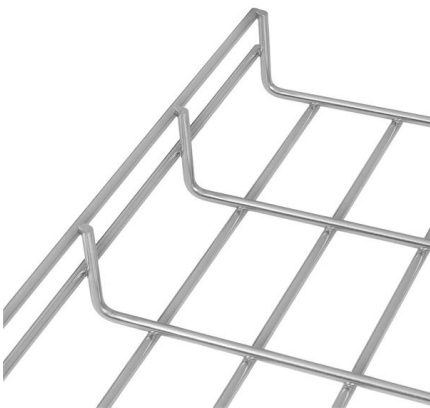

Research and Practice on Intelligent Operation and Maintenance of

With the explosion of digital demand, the intelligent operation of optical networks has also become an important development direction. At present, there are pa



MineOptimize , Mining , ABB

Our team then provides integrated products, services and solutions to help mining and mineral processing customers optimize their power and productivity,





Special issue on energy-efficient optical networks

All these efforts are the proof of a still flourishing research area looking for cutting-edge solutions toward energy efficiency in optical networks. This special issue solicited submissions of

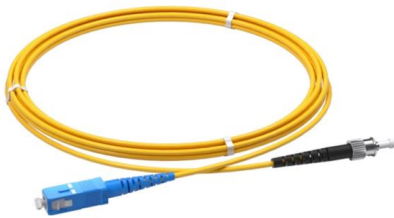

Monitoring and diagnostic technologies using deep neural networks for

Request PDF , Monitoring and diagnostic technologies using deep neural networks for predictive optical network maintenance , In recent years, optical networks have become

Design and Implementation of Solar-Powered Optical Fiber-Based

Silicate optical fibers of various core diameters and numerical apertures are characterized for illumination applications and their efficiencies are reported. The possibility of achieving optical

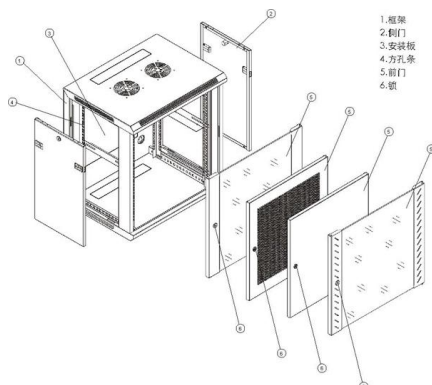

Design and Implementation of Solar-Powered Optical Fiber-Based

Download Citation , Design and Implementation of Solar-Powered Optical Fiber-Based Illumination and Communication System for Underground Coal Mines , Mine safety and quality of life



Energy Conservation in Passive Optical Networks: A Tutorial and Survey

We present a comprehensive survey of the energy conservation research efforts in PON starting from conventional PON to SDN based PON leveraging virtual and physical network functions. This article



Application of Low Cost Energy Efficient ZigBee Network

The experimental results indicate that a secure and stable ZigBee wireless network can be developed to overcome mentioned operational

Energy Efficiency in Optical Networks , Springer Nature Link

Energy efficiency is important for optical networks in terms of scalability, low-cost operation, and sustainability. At the same time, optical networks play an important role in enabling energy efficiency



Design of optical and wireless sensors for underground mining

The dilemma of wireless and optical node deployment, efficient coverage and sensing in underground mining is detailed. Therefore, we are interested on the case of optical sensors use in



Contact Us

For datasheets, pricing, or custom telecom energy solutions, please visit:
<https://koskolong.co.za>