



Adam Tas Corridor Energy

Enterprise Standard for Fiber Bragg Grating Demodulators





Enterprise Standard for Fiber Bragg Grating Demodulators

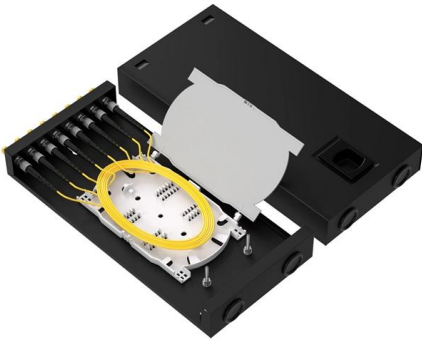

IEEE Standard for Fiber Optic Sensors--Fiber Bragg Grating

IEEE SA Standards Board Abstract: The purpose of this standard is to clarify definitions so that ambiguity in specifications can be eliminated to facilitate broad usage of Fiber Optic Bragg grating

Fiber Bragg Grating Sensors: Design, Applications, and

By evaluating the advancements in sensor design, implementation methods, and packaging techniques, we will assess the effectiveness of FBG



Fiber Bragg Gratings

In order to address this problem, an IEEE/SEAFOM working group has been formed with a remit to produce agreed terminology and working practices for fiber Bragg grating (FBG) based interrogators.

Fiber Bragg Grating

Fiber Bragg Grating (FBG) is defined as a passive filter device that consists of a diffraction grating created by periodic modulation of the refractive



index in the fiber core, allowing it to reflect specific



Fiber Bragg grating sensors for aerospace applications:

There are different types of fiber optic sensors, viz. intensity-based, polarization-based, grating-based, scattering-based sensors, reported in the

Fiber Bragg Gratings: Theory, Fabrication, and

In this article, basic rules of thumb and practical aspects concerning the use of FBGs are presented.



Fiber Optic Fiber Bragg Grating Sensing for Monitoring

This paper presents a review of the recent trends and the current state of the art in the application of fiber optic fiber Bragg gratings (FBG) sensing



Fiber Bragg Grating Technology , Frequently Asked

Frequently Asked Questions on Fiber Bragg Grating Technology & Systems Optical sensors based on Fiber Bragg Gratings (FBG) are becoming increasingly



P3461/D12, Jun 2025

Smart infrastructure can use distributed fiber optic sensors to monitor strain, vibration, and temperature. The standard expands the monitoring capability to include corrosion, crack detection and growth.

What Is Fiber Bragg Grating? The Ultimate Guide to

Fiber Bragg Grating enables precise strain and temperature sensing, offering reliable monitoring for structures, machines, and harsh environments.

LoRawan outdoor base station



Ultra-Low-Loss Fiber Bragg Grating Mode Scrambler Design

We present a mode scrambler design based on long-period fiber Bragg gratings for links employing graded-index transmission fibers with $D = 12$ guided spatial and polarization modes. In typical graded



AOC
QSFP28 to 4*SFP28
100G
OM3/OM4



Bragg Gratings , How it works, Application & Advantages

What are Bragg Gratings? Bragg Gratings, named after the British scientists William Henry Bragg and his son William Lawrence Bragg, are periodic



Optical Phase/Frequency Demodulation using Polarization

Our technique exploits the reflection characteristics of fiber Bragg gratings written in polarization-maintaining fibers to create a frequency discriminator, which is able to convert PM/FM signals into

fiber bragg grating

Find fiber bragg grating products, fiber bragg grating suppliers from China, Ecer help you directly contact with fiber bragg grating manufacturers.





Optimization of Fiber Bragg Grating Parameters for Sensing Applications

Bragg gratings manufactured by several different techniques are compared to demonstrate their suitability for different types of sensing applications. Several application focused examples are also

(PDF) Fiber optic Fiber Bragg grating sensing for

Keywords: Fiber Bragg grating (FBG); Fiber optic sensors; Electric machines; Drives; High voltage assets; Condition monitoring; Fault detection; In



Fiber Bragg Gratings: The Ultimate Guide

Introduction to Fiber Bragg Gratings Fiber Bragg Gratings (FBGs) are a crucial technology in the field of optics, with a wide range of applications in telecommunications, sensing,



Fiber Bragg Grating

Fiber Bragg Grating (FBG) is defined as a type of optical fiber sensor that operates as a Bragg reflector, allowing for the measurement of strain and temperature by tracking changes in its wavelength peak,

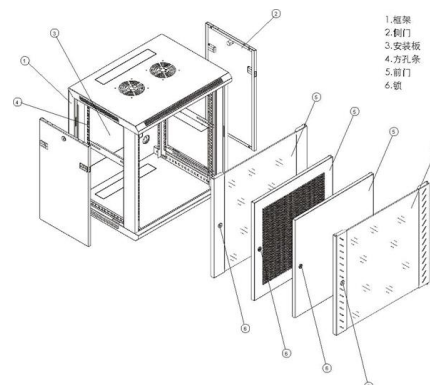

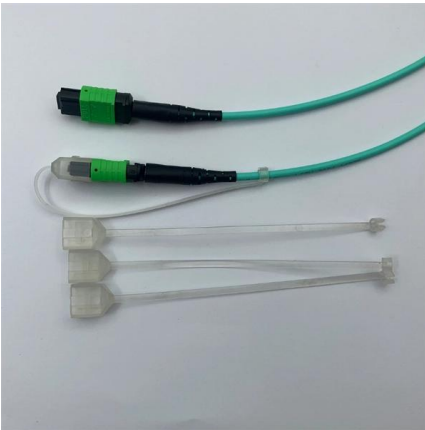

Fiber Bragg Grating Technology , Frequently Asked

Concise answers to the most frequently asked questions about optical strain gages and fiber bragg grating technology.

Fiber Optic Sensors--Fiber Bragg Grating Interrogator Standard

It also offers a list of the key performance parameters needed to describe fully a Bragg grating-based sensor system and to allow the end user readily to compare systems from different



Fiber Optic Sensors--Fiber Bragg Grating Interrogator Standard

Purpose The purpose of this standard is to clarify definitions so that ambiguity in specifications can be eliminated to facilitate broad usage of Fiber Optic Bragg grating sensors in a

Discrimination methods and demodulation techniques for fiber Bragg

Fiber Bragg grating (FBG) sensors are one of the most exciting developments in the fields of fiber-optic sensors in recent years.



Fiber Bragg Grating

Fiber Bragg Grating (FBG) is defined as a sensing technology that utilizes gratings inscribed in optical fiber to enhance strain measurements by shifting the Bragg wavelength of output light in response to



INFIBRA TECHNOLOGIES

The Fiber Bragg Grating (FBG) sensor is very high sensitive and versatile optical device for measuring several physical parameters including for example: strain,



Full article: Fiber Bragg grating demodulation through

Since the Bragg wavelength is a function of the fiber equivalent refractive index and the grating period, any physical parameter able to influence





Fiber Bragg Gratings: Theory, Fabrication, and

Here we offer a short explanation of FBGs provided as excerpts from the SPIE Tutorial Text, Fiber Bragg Gratings: Theory, Fabrication, and

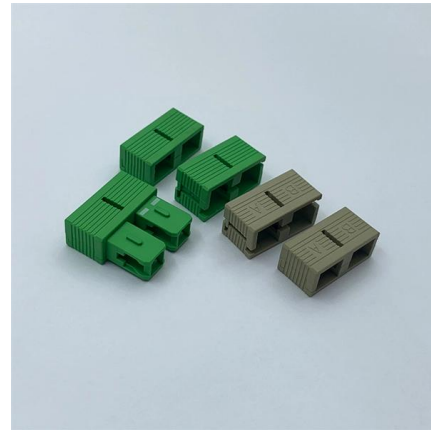

Bragg Gratings in Optical Fibers: Fundamentals and Applications

Despite the improvements in optical fiber manufacturing and advancements in the field in general, basic optical components such as mirrors, wavelength filters, and partial reflectors have been a challenge

In-line fiber demodulators for interrogation of Bragg grating sensors

Optical fiber Bragg gratings, first demonstrated by Hill in 1978, will see increasing deployment as sensors in smart structure applications due to their minimal insertion loss and small



Contact Us

For datasheets, pricing, or custom telecom energy solutions, please visit: <https://koskolong.co.za>