



**Adam Tas Corridor Energy**

# **Estonian Imported Integrated Wiring Cabinet 100kW**





## Estonian Imported Integrated Wiring Cabinet 100kW

---

### **KSTAR 100kW/200kWh outdoor All-in-one ESS cabinet**

It is suitable for various applications.



### **100kW 215kWh Cabinet Battery Energy Storage System**

In short, the 100kW 215kWh Modular Outdoor Integrated Cabinet Lithium Battery is an innovative power storage space remedy that integrates sophisticated modern



### **100kWh Smart PV Ess Cabinet**

Integrated PV and storage system with super wide PV input voltage; Small footprint and IP54 protecting grade for outdoor installation. Safe & Reliable High-performance battery cell, meet IEC/UL/GB



### **Rayleigh Instruments RI-ENERGYSET-3P-ESS-100-197**

The RI-ENERGYSET-3P-ESS-100-197 series form part of Rayleigh Instruments growing family of



renewable energy products. This all-in-one outdoor battery and

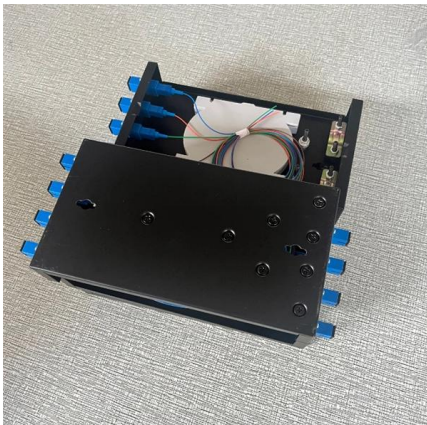

### 100KW 232KWh Industrial And Commercial Energy Storage Cabinet

Liquid-cooled 100kW 232kWh lithium battery ESS Integrated Solar Power Cabinet, an advanced high-voltage energy storage solution designed for industrial and commercial applications.

### ECO-E215WS Integrated Air-cooled Energy Storage

Product Name: ECO-E215WS Integrated Air-cooled Energy Storage Cabinet The air-cooled integrated energy storage cabinet adopts the "All in One" design concept,

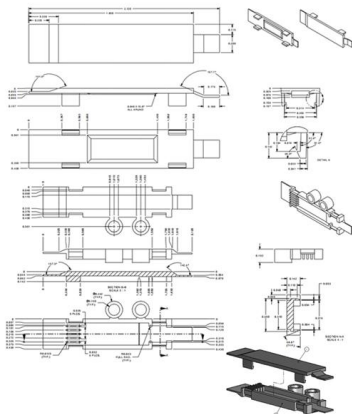

### All-In-One C& I ESS Cabinet , 100kW/ 215kWh , AZE

Introducing the All-In-One C& I ESS Cabinet - a high-performance, containerized energy storage system designed to deliver 100kW power output and 215kWh capacity in a single, integrated unit.



## 50kW/100kWh PV ESS All-in-one Cabinet Energy

Energy Cube 50kW-100kWh C& i ESS integrates photovoltaic inverters and a 100 kWh energy storage system. It includes battery cells, Battery Management



### Product Photography



## 100kW 215kWh All-in-One Battery Storage Cabinet

All-in-One Battery Storage System The iCON 100kW 215kWh Battery Storage System is a fully integrated, on or off grid battery solution that has liquid cooled

## 100kW/215kWh liquid cooled commercial energy storage cabinet

The 100kW/215kWh liquid cooled energy storage cabinet adopts an integrated design concept, which is a highly integrated energy storage product that integrates battery system, BMS, PCS, EMS, fire

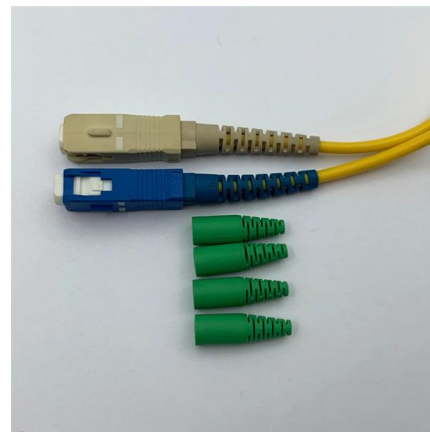

## 100KW 215KWh Industrial And Commercial Energy

CiFi SUN energy storage integrated cabinet series. Air-cooled 100kW 215kWh lithium battery ESS Integrated Solar Power Cabinet, an advanced high-voltage energy



### **100KW 232KWh Industrial And Commercial Energy Storage Cabinet**

CiFi SUN energy storage integrated cabinet series. Liquid-cooled 100kW 232kWh lithium battery ESS Integrated Solar Power Cabinet, an advanced high-voltage energy storage solution designed for

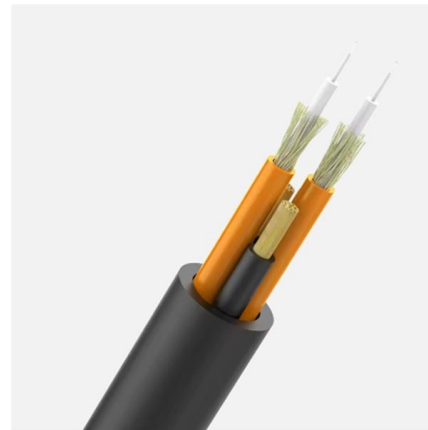

### **100kW/215kWh Integrated Energy Storage Cabinet as**

The 100kW/215kWh integrated energy storage cabinet is one of the classic solutions in recent development of C&I energy storage.



### **KSTAR 100kW/200kWh outdoor All-in-one ESS cabinet**

CATL high performance LFP battery Modular design. The energy storage system can be expanded by multiple 100kW/200kWh units. String monitoring optional. 75kW MPP trackers are integrated inside.





### **SolaX ESS-TRENE , All-In-One C& I ESS Cabinet**

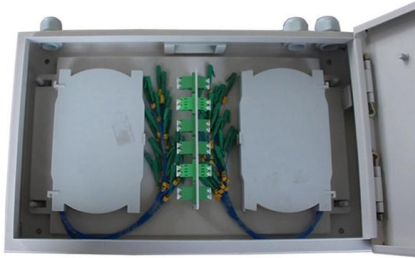

The SolaX ESS-TRENE is an all-in-one C& I energy storage cabinet, in air cooling model. Equipped with high-performance LFP cells, advanced energy

### **50kw 100kwh Commercial & Industrial ESS All-in-one**

Features Energy Cube 50kW-100kWh C& i ESS integrates photovoltaic inverters and a 100 kWh energy storage system. It includes battery cells, Battery Management



### **ESS Solar Energy Storage Battery Cabinet 215kwh 430kwh 1MWh All In One**

Namkoo NKB Series 215kwh commercial & industrial energy storage system adopts the all in one design concept. The cabinet is integrated

### **European Stock 100kW/200kWh C& I Energy Storage Cabinet All-in**

Our 100kW/200kWh Commercial & Industrial Energy Storage Cabinet is now available from European stock, enabling fast delivery and rapid deployment for factories, commercial buildings, data centers,



### 100KW/215KWh All-in-One Outdoor Lithium Inverter

Our solution is an all-in-one package: Battery packs, charge controller, BMS, EMS, and PcS, all integrated into a single unit with a highly efficient three-level topology



### 100kW 215kWh adayo distributed energy storage

Technical Specifications for 215kWh PV-ESS System 100kW 215kWh ADAYO distributed ESS cabinet for industry and commercial UPS solutions Introduction



### 100kw/215kWh ESS Liquid-cooling Energy Storage

SolarEast 100kw/215kWh ESS Cabinet is a liquid-cooling outdoor energy storage battery system cabinet suitable for energy storage.







### **100KWH/215KWH 768v 280Ah 3phase HV outdoor LiFePo4 BESS**

The Lithium Iron Phosphate (LFP) system is equipped with a Battery Management System (BMS) and a 768V 280Ah lithium battery. The



## **Contact Us**

---

For datasheets, pricing, or custom telecom energy solutions, please visit:  
<https://koskolong.co.za>