



**Adam Tas Corridor Energy**

# **European Outdoor Distribution Box Design and Installation**





## European Outdoor Distribution Box Design and Installation

---

### Indoor / Outdoor Distribution Boxes , SENTAL Export



If you lay cables, these must also be distributed. We offer a wide range of street cabinets, as well as indoor and outdoor distribution boxes.

### IDE Electric

Transparent window: Recommended for outdoor use: UV protection according to the ISO 4892-2 standard, method A: 1000 h. Supplied in individual packaging. When several items are sent together,



### Junction boxes, and distribution boxes for indoor and

Find out how junction boxes for surface-mounted installation, surface-mounted distribution boxes and terminal boxes can improve your electrical installation.

### Outdoor Distribution Box SHA Series

The SHA series provides 4 to 36 channels of modular design and can be flexibly configured to



meet various power needs. It has a rated voltage of 400V, a rated



### European Type Cable Branch Box

With flexible installation options, it simplifies power distribution and reduces maintenance needs, making it an ideal choice for modern grid infrastructure upgrades.

### TECHNICAL SPECIFICATION FOR OUTDOOR TYPE DISTRIBUTION FEEDER PILLAR BOX

1. Scope: This specification covers technical requirements of design, manufacture, testing at manufacturer's works, packing, forwarding, supply and unloading at store/site and performance of



### Technical Specifications for Outdoor LT Distribution boxes with

Scope: The scope of this specification covers Weather / Vermin proof LT distribution boxes (LTD) with controllers, MCCB, MCB, Bus bars, Contactors, CT's, Energy Meter, LT gas filled fixed capacitor, DC



## Premium Outdoor Distribution Box Solutions

Discover high-performance outdoor distribution boxes featuring advanced weather protection, flexible installation options, and smart monitoring capabilities. Perfect for residential, commercial, and



## Outdoor electrical distribution box

An outdoor electrical distribution box is a vital component in power management systems, designed to safely distribute electricity in external environments. These enclosures protect wiring, circuits, and

## Custom Dual-Mount European Standard Distribution Boxes with

Learn how tempered glass visibility, modular DIN rail layouts, flexible electrical enclosure design, and project-based compliance planning help contractors, OEMs, and facility teams build

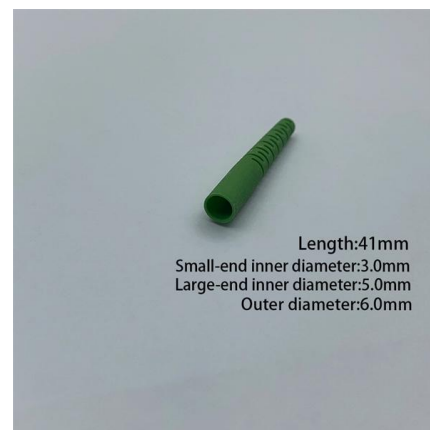

## Distribution Boards

Kabeldon distribution boards are specifically designed for outdoor installations and they come as pre-assembled systems, ready to install. They combine the advantages of the flexible IP-system with



## What Are the Advantages of a European Cable

1. Superior Safety Standards One of the most significant advantages of European cable distribution boxes is their adherence to stringent safety



## Teaching Video for European-Style Electrical Distribution Box

For European-style home electrical meter boxes: Refer to this video. For American-style ones: Check the corresponding video.

## 2025 European-Style Box-Type Substation Guide: From Design to Installation

Account for transportation, installation, and commissioning in the project schedule to avoid delays. Core Technologies of European-Style Box-Type Substations Technical specifications





### Microsoft Word

Continuity of the duct, screen or strip must be ensured at junction or distribution boxes. The link ensuring this continuity must be protected mechanically and against corrosion.

### Elsta Mosdorfer

Metering cabinets and installation distributor cabinets Perfectly suited to metering, measuring, and redistribution of electric energy or gas outdoors or indoors. The



### Customization of a complete distribution box

Learn the step-by-step process of customizing complete distribution boxes tailored to your needs. From requirement confirmation to design,

### Size determination, installation method and wiring mode

The distribution box is the central hub of the home circuit and the general control of our daily power consumption. It is an indispensable electrical equipment. If there



### **Indoor / Outdoor Distribution Boxes , SENTAL Export**

We offer a wide range of street cabinets, as well as indoor and outdoor distribution boxes. What do you need? By checking the box, you consent to the collection

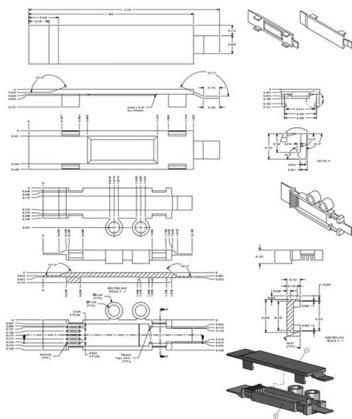

### **Electrical Power Distribution Box: A General Installation**

A practical general guide to installing and maintaining electrical power distribution boxes for international buyers. Includes safety best practices and



### **Outdoor Electrical Box with Breakers: Circuit Protection & Load**

If you're planning an outdoor electrical installation--whether for solar arrays, pool equipment, or landscape lighting--understanding outdoor electrical box with breakers is essential for





## Ultimate European-Style High-Voltage Cable Distribution

This drawing provides the exact specifications needed for the manufacturing, installation, and maintenance of HV cable distribution systems.



## Cable Distribution Box for Outdoor Distribution

Designed for underground or outdoor distribution systems, the Cable Distribution Box offers a tamper-resistant and weatherproof solution for medium voltage control

## How to Install a Distribution Box--A Comprehensive

Whether you are an electrical contractor or a construction brigade, knowing how to properly and safely install distribution boxes is the basis of



## Contact Us

---

For datasheets, pricing, or custom telecom energy solutions, please visit:  
<https://koskolong.co.za>