



Adam Tas Corridor Energy

Free consultation on Korean wavelength division multiplexers





Free consultation on Korean wavelength division multiplexers



Wavelength Division Multiplexing: An Overview & Recent

Wavelength division multiplexing (WDM) is an emerging technology that enables carriers to significantly increase transport capacity while leveraging existing fiber-optic equipment.

Wavelength Division Multiplexers (WDM) , Corning

Please briefly describe your wavelength management questions/needs in the comments section below. For example, CWDM vs. DWDM channel requirements,



South Korea Wavelength Division Multiplexer Wdm Market

The South Korea WDM market is characterized by rapid technological progress, including the deployment of higher-capacity systems such as 400G and 600G WDM solutions.

Wavelength Division Multiplexing Market

Wavelength division multiplexing (WDM) is a cutting-edge optical fiber communication



technology that focuses on multiplexing optical signals on a single fiber depending on color or wavelength.

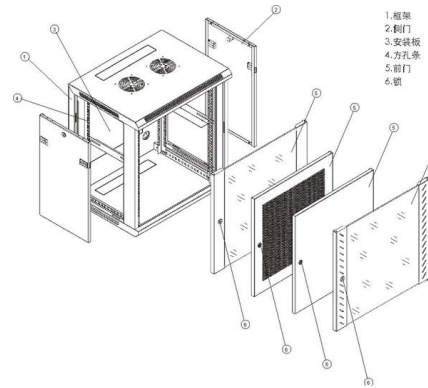

(PDF) Wavelength Division Multiplexing

Wavelength Division Multiplexing (WDM) is a significant improvement in optical communication. WDM is basically used for improving spectral efficiency



Wavelength Division Multiplexer Market

Wavelength division multiplexers enable this by allowing for the simultaneous transmission of various wavelengths, thereby maximizing the use of existing infrastructure.



Research on Optimization and Application of Wavelength Division

This paper discusses in detail the wavelength division multiplexing (WDM) technology, which effectively increases the communication capacity and transmission speed by simultaneously transmitting





What is Wavelength Division Multiplexing (WDM): A

Introduction to Wavelength Division Multiplexing (WDM) Wavelength Division Multiplexing (WDM) is a fiber optic transmission technique that combines

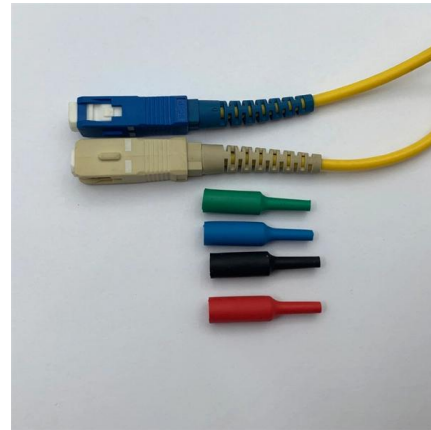

South Korea Wavelength Division Multiplexer (wdm) And

This is essential intelligence for decision-makers who need to move decisively and stay ahead in the rapidly advancing South Korea Wavelength Division Multiplexer (wdm) And Splitters

WDM: Wavelength Division Multiplexing

Explore the advantages and disadvantages of Wavelength Division Multiplexing (WDM), an optical multiplexing technique, in terms of bandwidth, security, and cost.



South Korea Wavelength Division Multiplexer Market (2025-2031)

South Korea Wavelength Division Multiplexer Market is expected to grow during 2024-2031



Dense Wavelength-division Multiplexing

Dense wavelength-division multiplexing (DWDM) revolutionized data transmission technology by increasing the capacity signal of embedded fiber. This increase means that the incoming optical



Wavelength Division Multiplexing (WDM)

Wavelength Division Multiplexing (WDM) Abstract Wavelength division multiplexing or WDM allows the combining of a number of independent information-carrying wavelengths onto the same fiber,

WDM Basics: Understanding Wavelength Division

WDM (Wavelength Division Multiplexing) technology is an ideal solution to get more bandwidth and lower cost in nowadays telecommunications





WDM 101 , Optical Communication , Corning

WDM Fundamentals Wavelength division multiplexing (WDM) can help network operators stay ahead of growing demand for bandwidth. Read on to learn the fundamentals of this useful technology.

South Korea Wavelength Division Multiplexer Module Market

What are the implications of regulatory shifts towards environmental sustainability on the deployment of Wavelength Division Multiplexer Modules in South KoreaâEUR(TM)s telecom sector?



Wavelength Division Multiplexers (WDM) , Corning

Explore wavelength division multiplexers (WDM), their applications, and products and learn why Corning is the best choice for WDM.

South Korea Wavelength Division Multiplexer Market Size, Revenue

The South Korea Wavelength Division Multiplexer Market Research Report delivers a sharp, evidence-based assessment of market size, growth trajectories, and emerging shifts that will impact



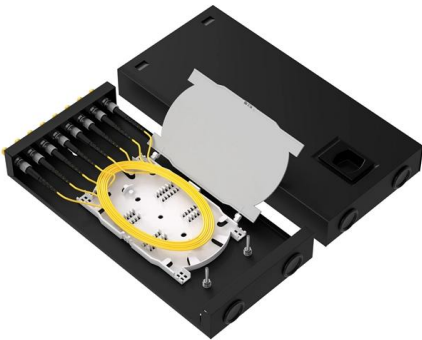

South Korea Dense Wavelength Division Multiplexers Market

South Korea Dense Wavelength Division Multiplexers Market was valued at USD 0.6 Billion in 2022 and is projected to reach USD 1.

High-Performance Wavelength Division Multiplexers

Wavelength division multiplexers are fundamental to the functioning and performance of integrated photonic circuits, with applications ranging from



Wavelength Division Multiplexing: A Guide to Fiber Optic

Wavelength Division Multiplexing (WDM) enables multiple optical signals to travel through a single fiber by using different wavelengths of light. This optical

Wavelength Division Multiplexers (WDM) Suppliers in Korea, South

Wavelength division multiplexers (WDM) are devices that combine light signals with different wavelengths, coming from different fibers, onto a single fiber.



Wavelength-Division Multiplexing: Boost Network

Discover how Wavelength Division Multiplexing (WDM) revolutionizes modern networks with expanded fiber capacity, scalability, and cost efficiency.



Wavelength division multiplexers and some experimental analysis in

Light shunting is becoming increasingly popular as the bandwidth required for information transmission in people's daily lives increases. The main subject of current information research is how to transmit



Wavelength Division Multiplexing - Buying Guide & Supplier List , RP

This wavelength division multiplexing buying guide provides technical background, comparison of major types, selection criteria, and an overview of suppliers.



Wavelength Division Multiplexing

Wavelength Division Multiplexing (WDM) is defined as a multiplexing technology used in fiber-optic transmission to maximize transmitted bit rates, enabling long-haul data, video, and voice



Contact Us

For datasheets, pricing, or custom telecom energy solutions, please visit:
<https://koskolong.co.za>