



Adam Tas Corridor Energy

French Co-packaged Optics PAM4





French Co-packaged Optics PAM4



224 GBPS PAM4, CO-PACKAGED AND NEAR-CHIP SYSTEMS

Placement of Flyover® cable solutions on, or near, the chip package improves transmission line density and extends signal reach in high-performance applications CPX: Electrically pluggable co-packaged

Marvell Unveils Co-Packaged Optics Technology Platform

By AIT News Desk On Mar 7, 2022 Marvell announced its first-generation cloud-optimized co-packaged optics (CPO) technology platform, to enable faster connectivity while reducing power consumption.



Evaluating Co-Packaged Optics (CPO) Performance

At the same time, to achieve larger capacity and higher integration, development of optical interfaces using Co-Packaged Optics (CPO) technology, which are fundamentally different from current

LUMENTUM UNVEILS NEXT-GEN CHIPS FOR SCALABLE AI DATA

Ultra-High-Power Lasers for Co-Packaged Optics
Lumentum's breakthrough ultra-high power



(UHP) 1310 nm DFB lasers are engineered for the demanding requirements of co-packaged



Various specifications optional



Innovations in Co-Packaged Interconnects for 224 Gbps PAM4 and

Whether you're going to the front panel or the backplane, with copper or optics, there are industry partners that can help with solutions along the way. These systems all launch from our Si

Aloe Semiconductor showcases 160-Gbaud PAM4 from a silicon

In optical input/output (OIO) and co-packaged optics (CPO), advanced silicon packaging plays a large role, and continuing to use pure silicon for the photonics, instead of adding new

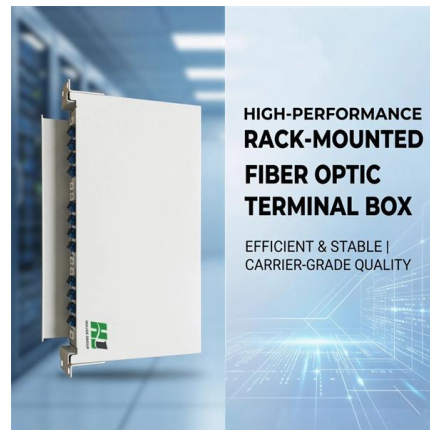

Samtec Si-Fly® HD 224 Gbps PAM4 Co-Packaged

Si-Fly® HD co-packaged and near-chip systems provide the highest density 224 Gbps PAM4 solution in today's market. Electrically pluggable co



Co-Packaged Optics

Co-Packaged Optics (CPO) is an advanced Silicon Photonics integration and packaging solution addressing next-gen bandwidth and power challenges. Its



OFC 2025: Marvell Interconnecting the AI Era

I see this 400G capability as a critical step towards 3.2T optical interconnects and 204.8T switches. Co-Packaged Platforms for AI Scale Up and

The Rise of Co-Packaged Optics: A Deep Dive into CPO

Enter Co-Packaged Optics (CPO), a transformative architecture where the optical engine moves inside the switch ASIC package. This article provides a



ECOC25: Marvell Highlights CPO, 800G COLORZ, and

Together, these developments point to a rapidly converging ecosystem where optics, DSP silicon, and packaging are co-optimized to meet



Optical Compute Interconnect v1.0 Brings NRZ + DWDM to AI Scale-Up

The architecture enables direct-drive or SerDes-minimized configurations, reducing electrical I/O power and supporting dense optical integration via co-packaged optics and chiplets.



Inside Co-Packaged Optics: 224 Gbps Systems with Si

Short electrical traces between ASIC and optical engines minimize insertion loss and reflections, enabling clean 224 Gbps PAM4 signaling. This is a

Monolithically integrated 112 Gbps PAM4 optical

We demonstrate a transmitter and receiver in a silicon photonics platform for O-band optical communication that monolithically incorporates a

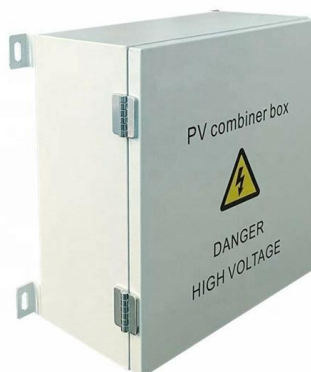



Wide-and-Slow VCSEL Co-Packaged Optics A Post-Copper Architecture

Wide-and-slow VCSEL co-packaged optics enables energy-efficient, low-latency, and scalable optical interconnects for next-generation AI datacenters.

Co-Packaged Optics Market Growth, Size, Share & Industry Trends

The Co-Packaged Optics market is set to reach USD 2869.94 million in 2026 and expand significantly to USD 7920.45 million by 2035, registering a CAGR of 13.53%.



C2PO: Coherent Co-packaged Optics using offset-QAM-16 for Beyond PAM-4

Abstract Co-packaged optics (CPO) has emerged as an ultimate solution for achieving the ultra-high bandwidths, shoreline densities, and energy efficiencies required by future GPUs and



A 112Gb/s PAM-4 XSR Transceiver for Co-packaged Optics

This talk presents a 112-Gb/s four-level pulse amplitude modulation (PAM-4) extra-short-reach (XSR) transceiver (TRX) for next-generation co-packaged optics application.

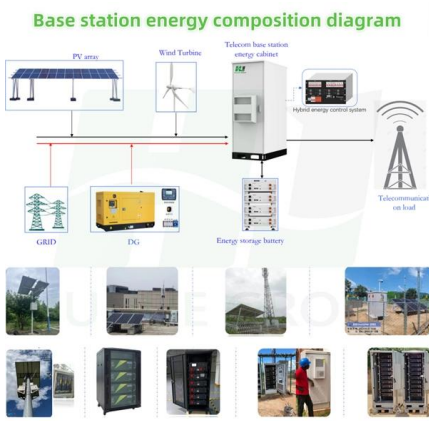

Omni Design Technologies Advances 200G-Class Co-Packaged Optics

Omni Design Technologies Advances 200G-Class Co-Packaged Optics IP Portfolio for Next-Generation AI Infrastructure New analog front-end IP development targets up to 224Gb/s PAM4

112-Gb/s PAM4 transmission using polymer-waveguide-coupled

A technology of co-packaged optics, which is mounting photonics integrated circuits and electronic integrated circuits on the same board, is essential to meet the demands of high-capacity

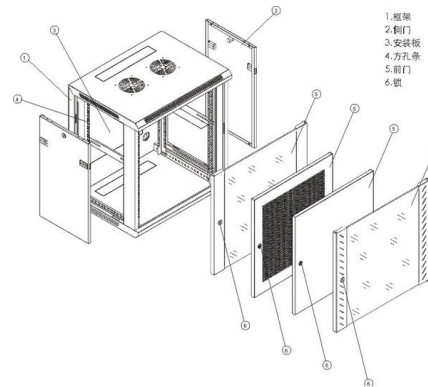

Optics Outpace Copper at OFC 2024

Bob Hult shares the phenomenal advances in high-speed optical communications showcased at OFC 2024, including interconnects for 200G per



AI infrastructure accelerates the shift to scalable optical systems

OFC 2026 confirmed that AI infrastructure is now the main demand driver for optical networking, with most major announcements focused on bandwidth scaling, power efficiency, and

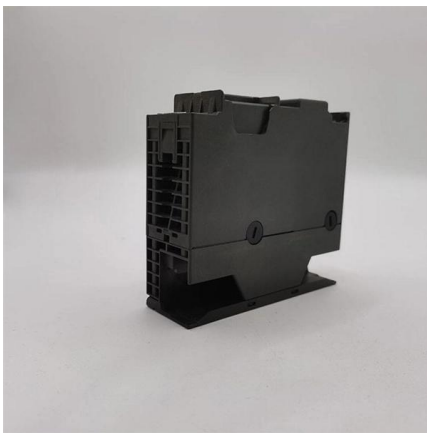

Feasibility Study and DSP Considerations for 400G/lane PAM4 Co

E2E PAM4 signaling required for linear drive architectures Technical feasibility of CPO and E/O/E channels using advanced analog and digital equalization techniques is of interest

Evolution of Co-Packaged Interconnects

To align with evolving system requirements and maintain future flexibility, Samtec's co-packaged SiFly HD CPX architecture offers: High-density



Contact Us

For datasheets, pricing, or custom telecom energy solutions, please visit:
<https://koskolong.co.za>