

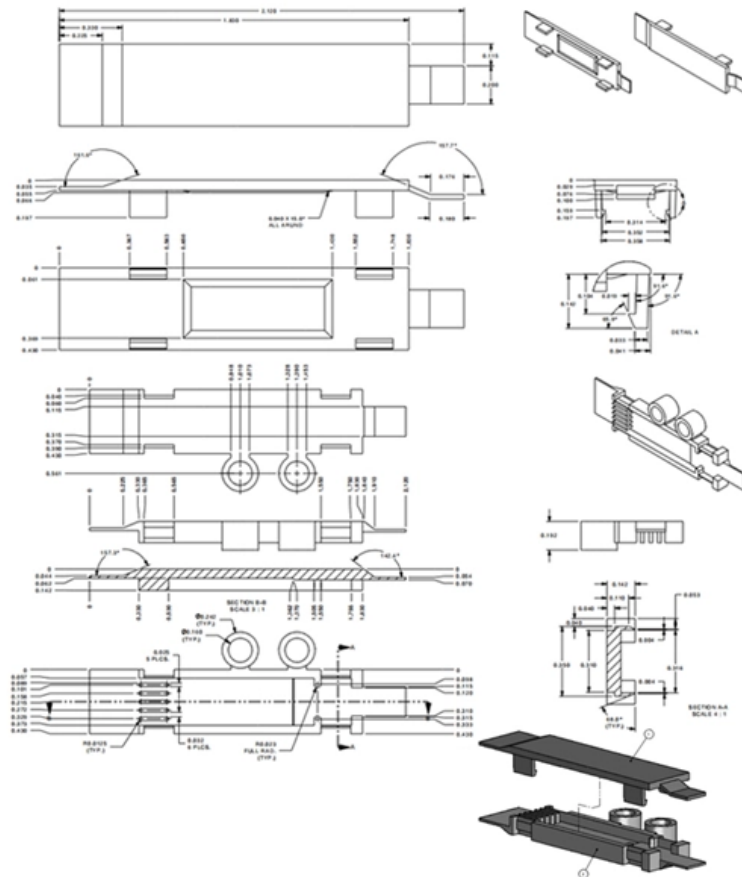

How many pigtailed can be connected to one optical splitter





How many pigtails can be connected to one optical splitter



How to Connect a Splitter to Another Splitter: A

Splitters are essential tools for distributing signals across multiple devices, whether in fiber optic networks, cable TV systems, or home

Fiber Optic Pigtail Meaning: What is it and How to

Fiber optic pigtail is an unbuffered optical fiber that has one end terminated with a fiber optic connector and the other end for splicing.



Pigtails vs. Splitters: Key Components in Fiber Optic

Pigtails facilitate secure and reliable connections between fiber optic cables and equipment, while splitters efficiently distribute optical signals to



Fiber Optic Splitters for PON Networks: 2025 Guide

What Are Fiber Optic Splitters in PON? Fiber splitters are passive devices that divide one



optical input signal into multiple outputs. In PON:
- One

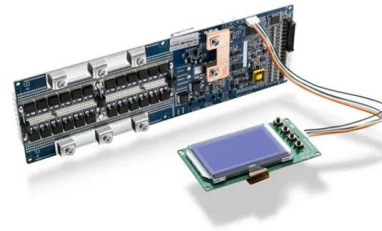

Basic Knowledge about Split Ratio and Insertion Loss of

The splitter ratio in fiber optic networks refers to how optical power is distributed among the output ports of an optical splitter. Expressed as a ratio or

Fiber Splitters The Role And Application Guide

Fiber splitters can effectively split optical signals into several signals of equal proportions and distribute them to different user terminals, thereby



Optical Splitters are used in PON (Passive Optical Network)

PON consists of an optical line terminal (OLT) at the service provider's central office and optical network units (ONUs) near or at the end users location. A PON reduces the amount of fibers and central



Optical Splitters: Split Ratios, Splitting Architectures & PON Network

This guide focuses on two critical aspects of optical splitters that define FTTH performance: split ratios (how signals are divided) and splitting architectures (how splitters are



Understanding Fiber Optic Pigtails: Types and

Characterized by having an optical fiber connector on one end and a bare fiber end on the other, they are primarily used to connect optical

Introduction to Passive Optical Network Splitter Architectures

In this configuration, typically more than one splitter is located in a cabinet some distance away from the OLT. Fewer fibers are used on the side of the network feeding the splitter.



The Working Principle and Application Scenarios of

FTTH networks rely heavily on fiber optic splitters to distribute signals from a central office to individual homes. For example, a 1×32 PLC splitter can connect 32



Optical Splitters: Split Ratios, Splitting Architectures & PON Network

The cascaded approach uses multiple splitters in "stages" to divide the signal--for example, a 1:4 splitter (Stage 1) feeds four 1:8 splitters (Stage 2), resulting in a total split ratio of 1:32.



Understanding Fiber Optic Pigtails: A Quick Guide

Pigtails can also be connected to splitters, which are used to split or distribute optical signals to multiple fibers. Overall, the working principle of a fiber

What Is Fiber Optic Pigtail and How to Splice It?

By Fiber Count Fiber optic pigtails could have 1, 2, 4, 6, 8, 12, 24 and 48 strand fiber counts. Simplex fiber optic pigtail has one fiber and a connector on





Comprehensive Introduction of Fiber Optic Splitter

Fiber splitter contains multiple input and output ends. Whenever the light transmission in a network needs to be divided, fiber optic splitter can be

How to Use Optical Couplers and Splitters in Fiber Networks

Optical couplers can split or join signals in fibers. You can connect many users to one port with 1:n or 2:n splitters. These devices work both ways, which helps strong network

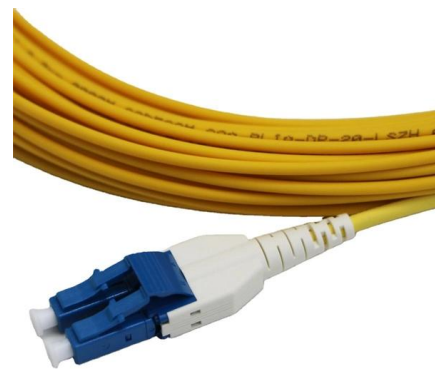

The Working Principle and Application Scenarios of

Fiber optic splitters are essential passive devices in modern optical communication systems, enabling the division of a single light signal into multiple outputs or

Optical Splitters in Modern Networks

Multimode optical splitters are optimized for 850nm and 1310nm operation, whereas single-mode optical splitters are optimized for 1310nm and



How Does a Fiber Optic Splitter Work

Centralized Splitting Centralized splitting means that the optical splitter is centrally distributed in the fiber distribution box, one end connects directly to

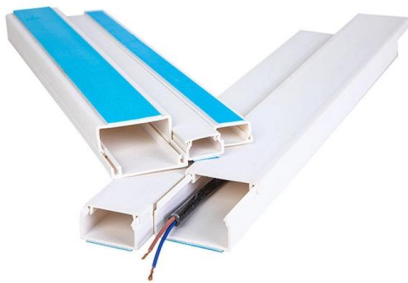

Split Ratios and Splitting Level of Optical Splitters

Thus, the PON network connects one OLT port to 32 ONTs. Cascaded Approach The cascaded approach may use a 1x4 splitter residing in an outside



Split Ratios and Splitting Level of Optical Splitters

The use of optical splitters in PON allows the service provider to conserve fibers in the backbone, essentially using one fiber to feed as many as





Comprehensive Guide to Optical Splitters

For devices above 1x4, higher splitting capacity can be achieved by connecting multiple 1x2 couplers together. This design method can improve the



What Is an Optical Splitter?

Fiber optic splitter, also referred to as optical splitter, fiber splitter or beam splitter, is an integrated waveguide optical power distribution device that

The Complete Guide to Pigtail Fibers: Simplifying

The Complete Guide to Pigtail Fibers: Simplifying Optical Connectivity Introduction In the world of fiber optics, where speed and precision reign

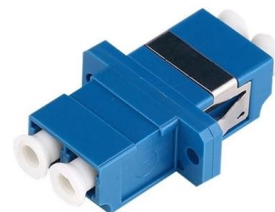

Coupler and Splitter Overview. It is generally accepted

Fiber optic splitters are important passive components used in FTTx networks. Two kinds of fiber splitters are most used: one is the traditional fused



Comprehensive Guide to Fiber Optic Pigtails , Gezhi Photonics

Fiber optic pigtails can be split into two categories: single-mode (yellow) and multimode (orange). Multimode fiber optic pigtails utilize 62.5/125 micron or 50/125 micron bulk multimode fiber



How to choose fiber optic pigtails?

Splicing of pigtails to each fiber in the trunk "breaks out" the multi-fiber cable into its component fibers for connection to the end equipment. High quality fiber pigtails

Understanding Fiber Optic Pigtails: A Quick Guide

Once the pigtail is spliced or terminated, it can be connected to other optical components to create a complete fiber optic network. This can include



Optical Splitters are used in PON (Passive Optical Network)

each fiber optic strand can be split many times and can serve many users. The majority of the existing networks are splitting the signal 2 times, while newer systems have gone even further by splitting 64



What Is Optical Splitter?

For instance, a 1×4 fiber optic splitter evenly divides an optical signal from one fiber into four separate fibers. To illustrate, a 1000Mbps bandwidth is



Contact Us

For datasheets, pricing, or custom telecom energy solutions, please visit:
<https://koskolong.co.za>