



Adam Tas Corridor Energy

How to inspect low-voltage busbars





Overview

This guide provides a comprehensive overview of dielectric testing for busbars, covering the key testing methods, steps, and practical considerations for ensuring the insulation integrity of busbars in power systems. How do you check and maintain busbars?

What are the faults of busbar?

What is bus bar in DB?

For complete safety instructions and precautions, always refer to the test equipment instruction manual. IEC 61439 is a standard developed by the International Electrotechnical Commission (IEC) that covers design verification for low-voltage electrical products and assemblies. We are able to carry out different types of accredited tests to improve the product and analyse potential failures.



How to inspect low-voltage busbars

Good Practice Rules For In-Process Inspection Of Low

Check that the horizontal and vertical busbar cross-sections are in accordance with the short-circuit and/or peak current. Check that busbars are in

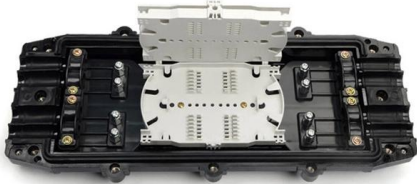

Inspection and Test Procedures for Metal-Enclosed

Inspection and test procedures for metal-enclosed busways consist of visual and mechanical inspection, electrical tests and testing the values.

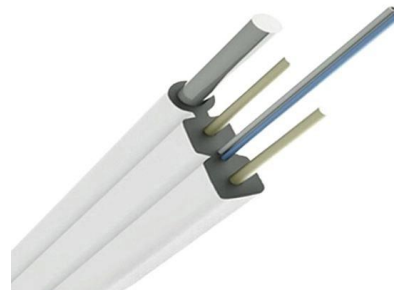

Safety Distance for Low-Voltage Busbars

Proper planning of safety distances in low-voltage busbar design and installation is critical for ensuring electrical performance, operational stability, and equipment safety. Adhering to industry standards



Busbar Testing Procedure

Discover the essential procedures & best practices for successful busbar testing. Our comprehensive post covers preparation,



equipment setup,



Effective Busbar Maintenance and Repair Methods

1. Introduction Busbars play a crucial role in electrical systems, facilitating the transmission of electrical energy from the source to various

Good Practice Rules For In-Process Inspection Of Low

The purpose of in-process inspection is to ensure product conformity after each manufacturing operation. This process concerns all the manufacturing



Busbar Processing & Installation: Your Ultimate Guide

Ever wondered how busbars, the unsung heroes of electrical distribution, are processed and installed? This article delves into the intricate





Busbar Inspection , Ensure Safety & Optimal Performance

Professional busbar inspection to detect wear, prevent failures, and ensure safe, efficient electrical system performance in any application.



Inspection of Busbar Systems for Clearance and Protection

In each of these scenarios, ensuring the correct clearance and protection of busbar systems is critical to prevent electrical shock, fire hazards, and equipment damage.

Design and installation of low voltage busbar trunking

Design and installation of low voltage busbar trunking systems (verified to BS EN 61439-6)
Last updated on November 23rd, 2017 Translate



How to Do Busbar Inspection and Maintenance on Ships?

Inspection of busbars in main and emergency switchboards on ships is important to prevent accidents caused due to electrical faults such as short circuits, fire etc. Learn how busbar



Busbar Stability Test Procedure - Step-by-Step Method

Learn the busbar stability test procedure step by step with clear explanations, practical tips, and engineering insights to verify busbar strength,

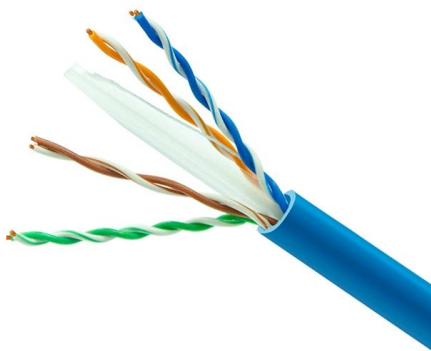

Copper Busbars , nVent ERIFLEX

Copper Busbars Heavy-duty power connections for the toughest tasks An alternative to multiple, large cables, ERIFLEX copper busbars are used for making strong and reliable power and earth-ground

Busbar Maintenance & Testing , Met Group

Busbar inspection and maintenance is often overlooked but is highly effective in keeping critical systems running. We offer full in-depth inspection and

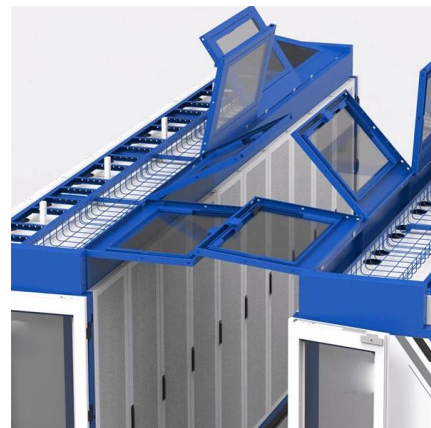



Three most important routine tests for successful

Three most important routine tests for successful verification of a low voltage switchgear By Edvard Csanyi Last updated on December 26th, 2025 ?

Technical Application Papers No.11 Guidelines to the construction

Technical Application Papers No.11 Guidelines to the construction of a low-voltage assembly complying with the Standards IEC 61439 Part 1 and Part 2

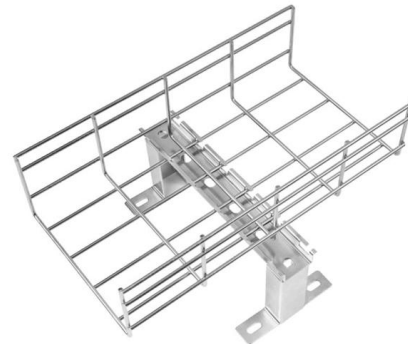

Low Voltage Busbar Trunking Systems Guide (BS EN

Guide to low voltage busbar trunking systems, verified to BS EN 61439-6. Covers applications, installation, testing, and safety.

How To Inspect And Maintain Ship Busbars? Marine Blog

Busbars are copper plates or bars used in ship main switchboards and emergency panels to conduct current from generators or from one electrical



Busbar Testing Procedure

Monthly: Clean the busbars, check the connections, and tighten the bolts and screws.
Quarterly: Use thermal imaging cameras to measure insulation



Tests on low voltage busbars

We carry out full electrical type tests on low voltage busbars in accordance with the IEC 61439-6 Standard to ensure that the products comply with regulatory

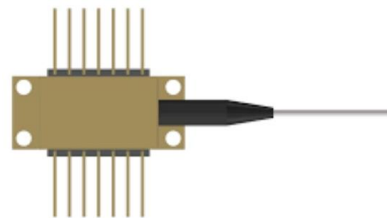

Guide to Low Voltage Busbar Trunking Systems Verified to BS EN

Guide to Low Voltage Busbar Trunking Systems Verified to BS EN 61439-6 5 Busbar Trunking System : An enclosed electrical distribution system comprising solid conductors separated by insulating



Dielectric Testing of Busbars: A Practical Guide for

This guide provides a comprehensive overview of dielectric testing for busbars, covering the key testing methods, steps, and practical considerations for

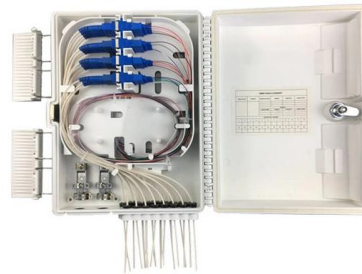

IEC 61439-1 and IEC 61439-6 Testing Procedure and

This three-part webinar series will take a deep dive into IEC 61439-1 and 61439-6 that defines the service conditions, construction requirements, technical

Bus Assembly Testing

The purpose of this Standard Work Practice (SWP) is to standardise and prescribe the method for testing high voltage bus assemblies. This includes air insulated busbars and enclosed busbars (such

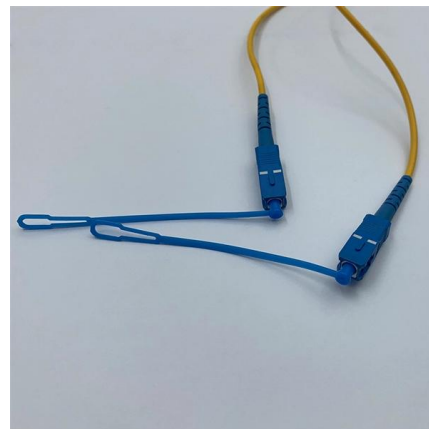

IEC 61439 Busbar Standard: A Guide to Low-Voltage

This standard covers busbars used for low-voltage assemblies, power distribution, photovoltaic power systems, and electrical energy control. The IEC



Contact Us

For datasheets, pricing, or custom telecom energy solutions, please visit:
<https://koskolong.co.za>