



Adam Tas Corridor Energy

Installation of ambient lighting in transparent electrical distribution box





Installation of ambient lighting in transparent electrical distribution



Junction Box IP66 Transparent Cover Distribution Box

EASY INSTALLATION: The distribution box has reasonable cable outlet, can be easily drilled, equipped with brackets and screws, easy to install. **WIDE APPLICATION:** This outdoor distribution box is

Transparent protective covers for electrical distribution panels

This product group is essential to ensure the safety and longevity of electrical panels and their components. Transparent protective covers are versatile, aesthetically appealing, and easily



REGULATIONS FOR ELECTRICAL INSTALLATIONS

Equipment: Any item for purposes such as generation, conversion, transmission, distribution or utilisation of electrical energy, such as machines, transformers, apparatus, measuring instruments,

ephesus-remote-distribution-installation-manual

Read and understand this entire manual and any additional site-specific installation documents



before attempting to assemble, install, or operate the luminaire. If you have any questions regarding the

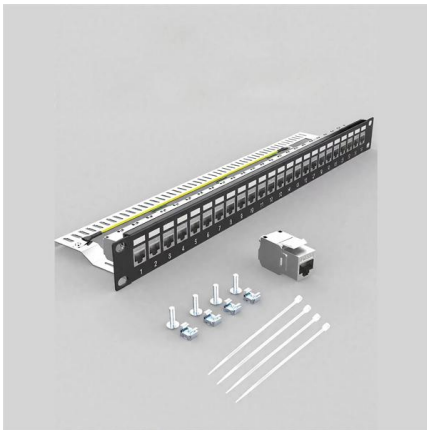

Temporary Power Distribution Boxes for Electrical

Temporary power distribution boxes for flexible electrical installation. Robust solutions for construction sites, events and temporary energy infrastructure.

How to confirm whether the installation location of the

The electrical distribution box plays a vital role in the power system. It is responsible for distributing electricity to various circuits and equipment.



MNS® Low Voltage Distribution Board and Power Cabinet

The dual-door structure design separates live parts from non-live parts to prevent electrical shock. All operations can be carried out on the parts protruding from the opening on the inner door. For design



14 tips for the installation of distribution board , China electrical

Measures: The electrical appliances and instruments on the lighting distribution box (board) should be firmly installed, flat and tidy, the spacing should be uniform, the copper terminals should not be loose,



Cautions and Requirements for Installation of

Distribution box is a low-voltage distribution device which assembles switchgear, measuring instruments, protective appliances and auxiliary equipment in a closed

Understanding Distribution Boxes: A Comprehensive Guide

Learn what a distribution box is, its types, and how to choose the right one for your project. Includes clear examples and expert tips.





Technical Requirements for Lighting System Installation

Lighting company shall carry out the installation of various lighting equipment as indicated in the approved drawings. The work shall include unloading, storing,

Embedded Installation Of Distribution Box

According to the installation size of wall mounted (surface mounted) terminal combination electrical appliances, first drill bolt holes or embedded wood bricks, then open the upper cover of the

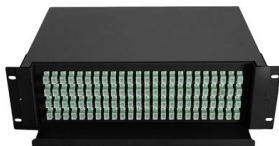

ephesus-remote-distribution-installation-manual

The Distribution Box manages the AC and DC electrical path for up to 6 qty PAC Boxes through the entire Remote Power System. The wiring can be separated into five main routes: (refer to page 3 to

The installation requirements for the distribution box

Introduction
Understanding The Components of A Distribution Box
Selecting The Right Distribution Box
Site Preparation and Location Requirements
Electrical Connections and Wiring
Compliance with Standards and Regulations
Conclusion
What Is a Distribution Box?
A distribution box, also known as a power



distribution unit, is a critical component in any electrical system. It is the control center for electricity in your home or business. It takes the electrical power coming into the building and distributes it to different circuits. Each circuit then powers various device

Why Proper Installation Matters

Installing a distribution box correctly is about more than just making sure the lights turn on. It's about safety, efficiency, and reliability. A poorly installed distribution box can lead to a host of problems. These include electrical fires, short circuits, and even complete power failures. Proper installation ensures tha

See more on eabel lucyelectric

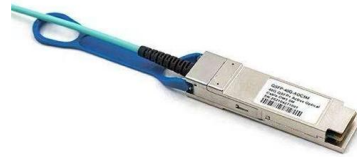

Outdoor Cut Outs and Distribution Boxes - Lucy Electric

Our Products Lucy Electric's range of low voltage outdoor cut outs and distribution boxes is engineered for durability, safety, and ease of installation in demanding

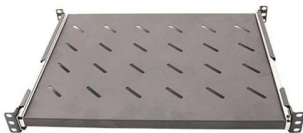

Understanding Distribution Boxes: A Comprehensive Guide

support safer operation in electrical systems For this reason, distribution boxes are widely used in homes, commercial buildings, industrial

Outdoor Transparent Electrical Box: Complete Buying Guide, Uses,

Complete guide to outdoor transparent electrical boxes. Learn how to choose, install, and protect outdoor wiring with clarity, safety, and confidence.





Outdoor Transparent Electrical Box Installation Guide: Step-by-Step

Learn how to install an outdoor transparent electrical box step by step. Protect outdoor wiring, avoid mistakes, and ensure long-lasting safety.

Installing Interior Ambient Lighting: What You Need to

With the right equipment and a little know-how, you can install car interior ambient lighting or have it installed by an experienced mechanic.

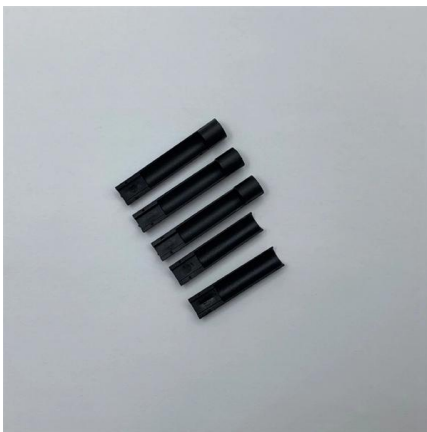

Electrical Distribution Boxes for Power Distribution

The Wieland distribution boxes, in compliance to IEC 61439, together with our installation connector systems, in compliance to IEC 61535, as well as its system

Understanding Distribution Boxes: Your Guide to Power

Like every other electrical task, installing a distribution box requires your attention for details, adherence to important electrical codes, and a

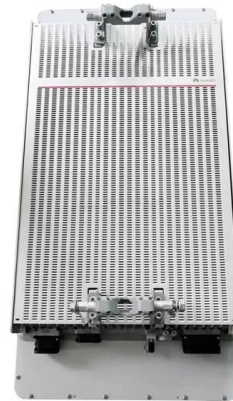

What is an Electrical Distribution Box? A

An electrical distribution box is often called the control hub of a building's electrical system, and for good reason. It's where power from the main



Distribution Protection Box, IP65 Transparent Cover

Distribution Protection Box, IP65 Transparent Cover Electrical Box, ABS Power Supply Electronic Junction Box for Circuit Breaker Indoor on The Wall 3 Way,

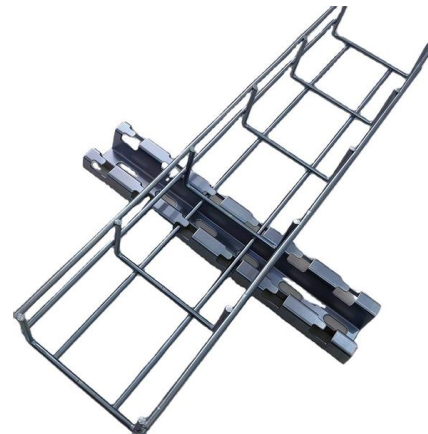

How to Install a Distribution Box--A Comprehensive

If your distribution box is installed outdoors and exposed to rain and sunlight, you need to select an electrical enclosure with a higher protection level,





Outdoor Transparent Electrical Box: Complete Buying Guide, Uses,

Whether you're installing lighting fixtures outdoors, solar components for your business, CCTV systems or even automation controls, it is important that you do so using a high-quality



Contact Us

For datasheets, pricing, or custom telecom energy solutions, please visit:
<https://koskolong.co.za>