



Adam Tas Corridor Energy

Is the AC distribution box grounded





Overview

26 mm² (10 AWG) ground wire must be used, and in all other markets a 6 mm² must be used. AC ground is the reference point for alternating current (AC) systems, providing a safe path for fault currents and helping stabilize voltage levels. Ungrounded or floating is now common with transformerless inverters, which rely on ground-fault detection interrupters (GFDI) for safety.



Is the AC distribution box grounded



Three Requirements and Three Functions of AC Power Distribution Boxes

AC power distribution boxes should be equipped with stable low-voltage electrical components and have sufficient allowance to ensure reliable system operation. Maintenance and Repair The AC power

Single & Three Phase Grounding

The grounding of three-phase circuits at the facility of a user of electric power may have a different appearance from that of the utility's grounding practices. In any



Air Conditioner Grounding Explained: Essential Knowledge for

In this blog post, we will delve into the question of whether an air conditioner needs to be grounded, exploring the reasons behind this requirement and the potential consequences of

Electrical Grounding Homeowner's Guide and How It Works

You're right. But with grounding, the term also includes metal appliance frames, junction boxes,



conduit and other metal things that don't normally carry, or use, electricity. These "non-current

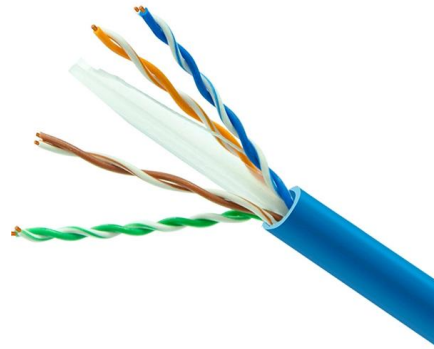

System and Equipment Grounding Safety - Power

The system ground is a special circuit designed to protect the entire distribution system of a residence. Equipment ground is essentially a circuit



Phases and wires in distribution of AC power

Distribution of AC power AC power transmission is always at high voltage and mostly by 3-phase system. The use of single-phase system is limited

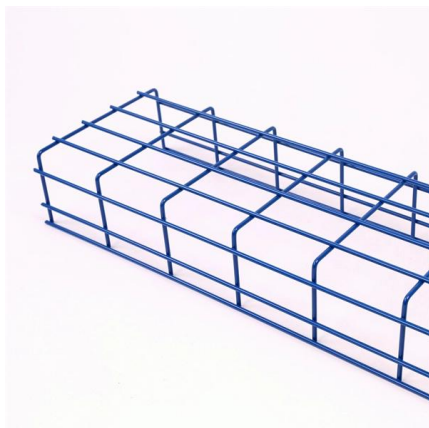

HVAC Grounding and Bonding Essentials

Discover the importance of proper grounding and bonding in HVAC systems. Learn how to ensure safety and efficiency in your installations.



Grounding Practices in Power Distribution Systems

It is absolutely necessary to implement efficient grounding in distribution systems in order to guarantee the safety, dependability, and performance of the electrical



JLC Field Guide: Grounding

JLC Field Guide: Grounding The purpose of grounding is safety: A ground wire generates a short circuit and trips the circuit breaker or fuse when

How to ground the low voltage distribution box?

The low-voltage distribution box, as a device for regulating the circuit system, needs to be so. How should the low-voltage distribution box be grounded? Now let's



Electrical grounding explained , Tameson

Discover the importance of electrical grounding and how it prevents equipment damage. Learn more about safe current dissipation techniques here.



Is my circuit breaker box grounded? If not, can it be?

It's unlikely that your service panel ("circuit breaker / fuse box") is not grounded. That could lead to all sorts of weird problems, not to mention that it

Mechanical drawing

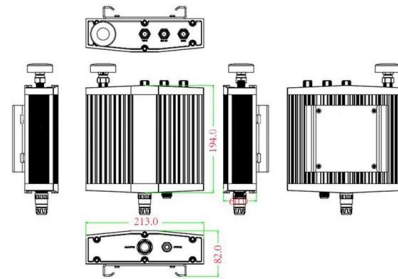

DISTRIBUTION BOX

Each DISTRIBUTION BOX and controller must be grounded. On the US market, a 5.26 mm² (10 AWG) ground wire must be used, and in all other markets a 6 mm² must be used.

Grounding Practices in Power Distribution Systems

Measurements of ground resistance, checks for corrosion, and verification of connections are all included in this responsibility. Distribution System Grounding





Air Conditioning Distribution Box: Essential Guide to Function, Types

This article explains what a distribution box does, typical configurations, sizing guidelines, installation considerations, and maintenance tips to help facility owners and homeowners

Difference Between AC Ground and DC Ground

In power distribution systems, AC ground is typically connected to the neutral wire and the earth (physical ground). In circuits, it helps prevent electrical noise and



Understanding Distribution Boxes: A Comprehensive Guide

A distribution box, also known as a power distribution box or electrical distribution box, is used to distribute electrical power safely to multiple

Do You Need To Ground An Inverter? (Safe Measures)

The grounding terminal of the AC terminal bus bar. Neutral grounding connection inside an electrical breaker panel box. Earth groundwater copper



Does the Distribution Box Door Need Grounding? Safety Standards FAQ

Hey there! If you've ever found yourself scratching your head over whether that metal door on your distribution cabinet really needs a grounding wire, you're not alone. In factories, construction sites,

Three Requirements and Three Functions of AC Power Distribution

The main grounding point is usually welded to the framework at the bottom of the cabinet, and the grounding point of the instrument panel should be connected to the cabinet, forming a complete

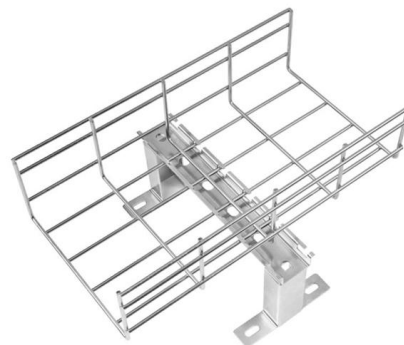

Inverter AC/DC Grounding & Bonding: Safety Guide

Lenders and insurers increasingly review grounding and bonding documentation. A poorly wired bond is not just unsafe--it can void insurance or



7. Ground, earth and electrical safety

Grounding is needed for electric safety and it also creates a reference point in a circuit to which voltages are measured. Earth is a direct physical connection to the Earth. This is usually done by driving a



Grounding System Installation Standards for Distribution Boxes and

Your distribution box is mission control for electricity in any building. When grounding fails here, it's like having a spaceship without a heat shield--everything inside becomes vulnerable to surges, faults,

Introduction to Power Distribution & System Grounding

ISOLATED GROUND An isolated ground is also referred to as a "technical ground" or "isolated single-point ground." Equipment that is connected to an "isolated



What is the AC distribution box?

Application of AC Distribution Box AC distribution boxes are widely used in mobile, microwave, tower base stations and their communication rooms for AC power distribution. Its main function is to



Electric system ground system inspection

Electrical ground system inspection procedures & checklists. This document discusses procedures the inspection of the grounding system components of a building electrical system when performed by



To Ground Or Not To Ground

For more updated information, read this article about grounding in the 2023 NEC. Does the National Electrical Code (NEC) require a 480-volt (V), three-phase, 3

How to Ground an Electrical Panel: A Complete Guide

Learn how to ground an electrical panel step-by-step. Ensure safety, code compliance, and protect your home from electrical hazards.





AC Distribution Box (ACDB) , Key Role in Solar Power

The AC Distribution Box (ACDB), also called the AC Distribution Board, is a key part of an Electrical Distribution System. Its main job is to control

Contact Us

For datasheets, pricing, or custom telecom energy solutions, please visit:
<https://koskolong.co.za>