



Adam Tas Corridor Energy

Ivory Coast High Return Loss Adapter G 652





Ivory Coast High Return Loss Adapter G 652



Selection of different ITU-T G.652 cabled -fibers in optical fiber networks

Abstract The selection of right fiber or cable in network deployment is very critical due to high deployment costs. In this paper, various operational factors affecting 100G transmission over

All-Solid G.652.D Fiber with Ultra Low Bend Losses Down to 5 mm

We demonstrate the feasibility of all-solid G.652.D fibers that exhibit bend losses 10 times lower than ITU-T recommendation G.657.B and 005 dB/tum at 5 mm bend radius at 1550 nm.

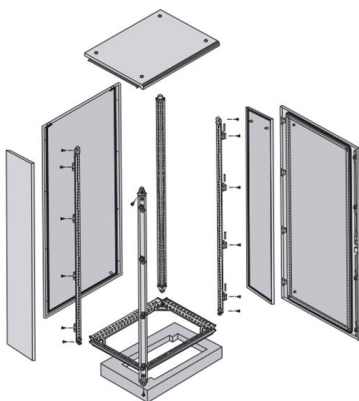

Ivory Coast Travel Adapter Kit , Going In Style

Ivory Coast Adaptor Plug Set allows you to plug in your US appliance into Ivory Coast wall outlet. Deluxe Adapter Kit: Includes two adapters and ships Priority

Everything You Should Know About Return Loss

Usually, return loss is measured using a directional coupler. Therefore, these devices are



studied in this article as well, including the measurement setup which is



What Is G.652 Fiber? G.652 vs G.652.D, G.652 vs

G.652 fiber is designed to have a zero-dispersion wavelength near 1310 nm, therefore it is optimized for operation in the 1310nm band and can also

2.8: Return Loss, Substitution Loss, and Insertion Loss

The output return loss is calculated looking into Port 2 of the two-port, where now the termination at Port 1 is just the source impedance. Figure 2 8 1:



Evolution of Singlemode Fibers

The singlemode fibers ITU-T G.657.A1 and ITU-T G.657.A2 are interoperable with the standard singlemode fibers ITU-T G.652.D in terms of geometrical and mechanical parameters as well as in



G.652.D vs G.657.A1/A2 Optical Fibers : Which Is Better

A practical guide for selecting between G.652.D and G.657 fibers. Compare specs, bending loss, MFD, PMD, and cost considerations to make the



ITU-T Rec. G.652 (11/2009) Characteristics of a single-mode optical

Recommendation ITU-T G.652 describes the geometrical, mechanical and transmission attributes of a single-mode optical fibre and cable which has zero-dispersion wavelength around 1310 nm.

Typical loss profiles of G.652 and G.655 fibers.

This solution implements transmission over a wider spectral range within the low-loss region of the widely deployed singlemode optical fibers, namely the ITU-T

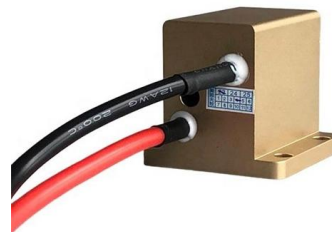

G.652

G.652 Fiber Applications Long-distance communication: The low attenuation and low dispersion characteristics of G.652 fiber make it the first

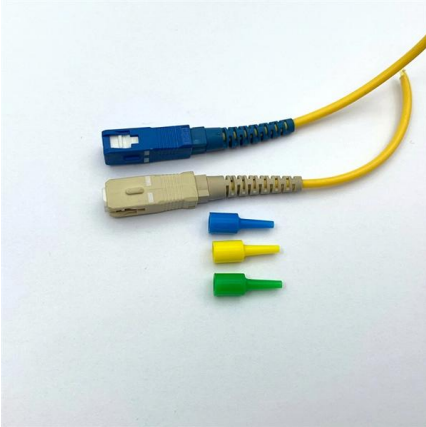

Insertion Loss vs Return Loss in Fiber Connectors

Learn what insertion loss and return loss are in fiber connectors, how they are measured, what causes poor performance, and how to reduce signal loss.



Single Mode Fiber Comparison: G.652 vs G.655

ITU-T G.65x series is a commonly known single mode fiber standard category, which can be further divided into G.652, G.653, G.654, G.655, G.656,

G.652.D Single-Mode Optical Fibre Specifications

Parameters are subject to change without notice.





Comparison of Ultra-Low-Loss G.652B Fiber and G.652D Fiber

How to extend the repeaterless transmission/sensing distance is the main demand for power grid as higher requirements are proposed for the optical transmission/sensing system. Although many

Travel adapter for Ivory Coast , Plugs and outlets in Ivory Coast

Heading to Ivory Coast? Make sure to check if you need a universal travel adapter, so you're always prepared. Read on for more!



G.652.D vs G.657.A1 vs G.657.A2: What's the

Explore the differences between G.652.D, G.657.A1, and G.657.A2 fiber optic cable specifications. Learn about their unique characteristics, bend

G.652 Fiber: Differences and Applications of Each

Conclusion G.652 fiber, in its various subcategories, has evolved over the years to meet the ever-increasing demands of modern communication

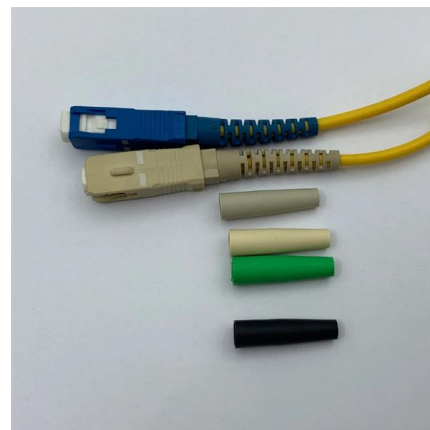



Sandblasting surface treatment process
Wear resistant, waterproof, rustproof, environmentally friendly, beautiful and generous, long service life.

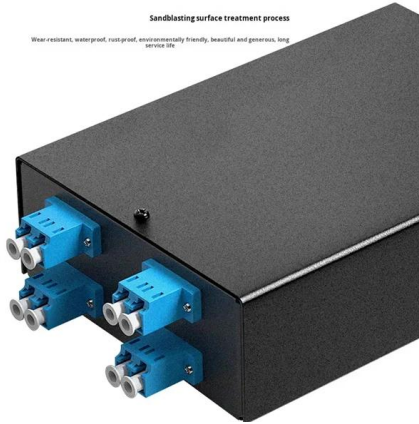

Tax rates in the Ivory Coast

Learn about taxes in the Ivory Coast. Find out information on corporate tax rates, individual income tax or consumption taxes.

Enhanced Single-Mode Fibre ITU-T G.652

APPLICABLE STANDARDS IEC / EN 60793-2-50
type B-652.D ITU-T Recommendation G.652.D



G.652D vs G.657A1 vs G.657A2: The Complete Guide

Explore the technical differences in G.652D vs G.657A1 vs G.657A2 fibers. Learn about bend radius, MFD compatibility, and FTTH network splicing loss.

Reusing Single-mode Fiber? Here's What the G.652D

Although G.652C and G.652D both offer excellent capabilities for shorter, unamplified metro networks and access networks, they do not fully





SRG Clip-ON-Adapter Jumbo 35mm Type 652

SRG Clip-ON-Adapter Jumbo 35mm Type 652 - Useable for Spain, France, Ireland, Norway, Finland, Denmark, Sweden, Portugal.

Typical chromatic dispersion coefficient of G.652 and

Download scientific diagram , Typical chromatic dispersion coefficient of G.652 and G.655 fibers. from publication: Opportunities and Challenges of C+L



ITU-T Rec. G.652 (11/2009) Characteristics of a single-mode optical

The ITU-T G.652 fibre was originally optimized for use in the 1310 nm wavelength region, but can also be used in the 1550 nm region. This is the latest revision of a Recommendation that was first created

Single Mode Fiber: ITU-T Standard G652x

G.652 fiber is designed to have a zero-dispersion wavelength near 1310 nm, therefore it is optimized for operation in the 1310nm band and can also operate at



All-Solid G.652.D Fiber with Ultra Low Bend Losses

Abstract We demonstrate the feasibility of all-solid G.652.D fibers that exhibit bend losses 10 times lower than ITU-T recommendation G.657.B and 0.05

Ivory Coast electrical outlets : need a travel adapter?

What type of power plug in Ivory Coast? Do I need a travel adapter to travel to Ivory Coast? Can I plug my phone or my computer to electric outlets in ivory-coast? Find the answer on My Travel Adapter.



Assessment on the Achievable Throughput of Multi-Band ITU-T G.652

Abstract--Fiber-optic multi-band transmission (MBT) aims at exploiting the low-loss spectral windows of single-mode fibers (SMFs) for data transport, expanding by the available ~11x bandwidth of C-band



Contact Us

For datasheets, pricing, or custom telecom energy solutions, please visit:
<https://koskolong.co.za>