



Adam Tas Corridor Energy

Lighting Distribution Box Wiring Method and Price





Lighting Distribution Box Wiring Method and Price

Electric Panel Installation Method Statement



This document provides a method statement for installing and terminating electric panels and distribution boxes. It outlines 4 steps: 1) Pre-installation preparation

Lighting Distribution Panel

The products of low-voltage distribution boxes have obtained the national 3C certificate and can produce distribution boxes with protection grade of IP65 and

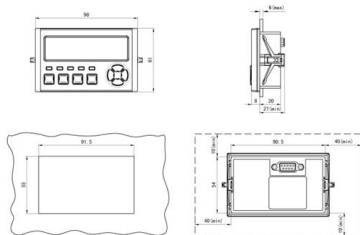

A Complete Guide to Domestic Lighting Wiring Diagrams

Learn how to wire your domestic lighting with this helpful diagram. Understand the different connections and components needed for a safe and efficient lighting

How to Choose a House Distribution Box , CHINT global

A well-chosen distribution box ensures the safety and efficiency of your household electrical



system. This article guides you through selecting a



Size determination, installation method and wiring mode

Next, let's introduce the wiring mode, installation method and size determination of the distribution box, For your reference. (1) Wiring method of distribution box.

Distribution Board Wiring Diagram For Single Phase Wiring

When we start a project of electrical wiring the first and main control point of wiring is the distribution board. Distribution board wiring is very important

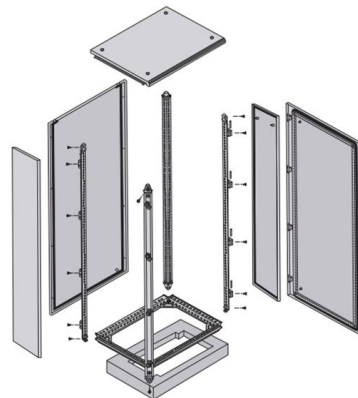

Lighting Circuits using junction boxes

Lighting Circuits Lighting circuits using junction boxes. Junction Boxes An alternative method, this uses the same wiring principles as the looped ceiling roses, but here

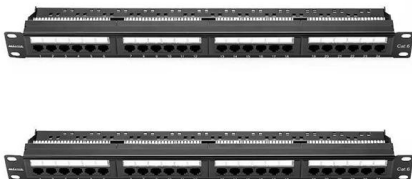



High-Quality Electrical Lighting Distribution Boxes Explained

These versatile components are essential for ensuring safe and efficient operation of lighting installations in diverse settings, from street lighting to commercial buildings. In this comprehensive guide, we'll



Distribution Box Wiring Steps

?Wiring Direction?: Wiring between the main circuit breaker and each branch circuit breaker in the box generally goes on the left, and the wiring out of

Explore Distribution Boxes for Every Setting with Different Types

Distribution boxes act as the central hub, receiving the main electrical supply and dividing it into designated circuits for lighting, outlets, and appliances. They provide a safe and organized way

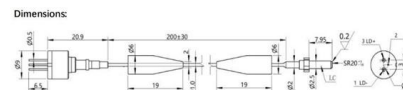

The installation requirements for the distribution box

Learn how to install a distribution box safely and correctly. Covers wiring, placement, standards, and expert tips for a compliant setup.



DIY Wiring a Consumer Unit and Installation

Method of Wiring Sub Circuit wiring has been discussed in detail for 1W Light, 2W Light, 5A, 13A and 16A Socket outlets etc. These needs to be wired prior to wiring

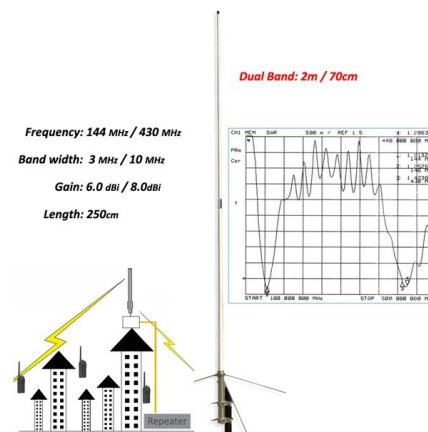

How to Install a Cable Distribution Box Safely and

Reliable cable distribution boxes ensure safe, efficient power management for residential, commercial, and industrial systems. Learn



What are the requirements for lighting distribution box wiring?

Lighting distribution box wiring is a very critical step when installing lighting circuits. The following are some basic requirements for wiring: Select the appropriate wire: The appropriate wire specification





Electric Panel Installation Method Statement

METHOD STATEMENT FOR Electric panel and distribution box installation and termination - Free download as PDF File (.pdf), Text File (.txt) or read online for



A Step-by-Step Guide to Wiring an Electrical Panel Box

Find out how to properly wire an electrical panel box with a comprehensive diagram and step-by-step instructions.



Wiring a Lighting Junction Box: A Step-by-Step Guide

Learn how to properly wire a lighting junction box for safe and efficient electrical connections. Step-by-step guide for professional results.



Lighting Accessories , Power Distribution Boxes

Power Distribution Boxes for Safe & Organized Lighting Power Management Explore Gladiator Lighting's collection of power distribution boxes, engineered to provide



How to wire a DB - Distribution Board Wiring -

Through the MCB phase lines are distributed to electrical wiring for lighting, fixed devices, and power distribution points. This type of arrangement is

The Complete Guide to Distribution Box: Installation, Types & More

A distribution box, also known as a distribution board, electrical panel, or breaker box, is an enclosure that houses electrical components responsible for distributing electricity throughout a



What are the requirements for lighting distribution box wiring?

In short, when wiring the lighting distribution box, appropriate wires and terminals should be selected, and the wiring should be carried out in strict accordance with the national electrical safety standards.



Understanding Distribution Boxes: Your Guide to Power

Weatherproof Distribution Boxes These serve specific outdoor purposes, with rain, dust, and extreme temperatures sealed shut, protecting any



Contact Us

For datasheets, pricing, or custom telecom energy solutions, please visit:
<https://koskolong.co.za>