

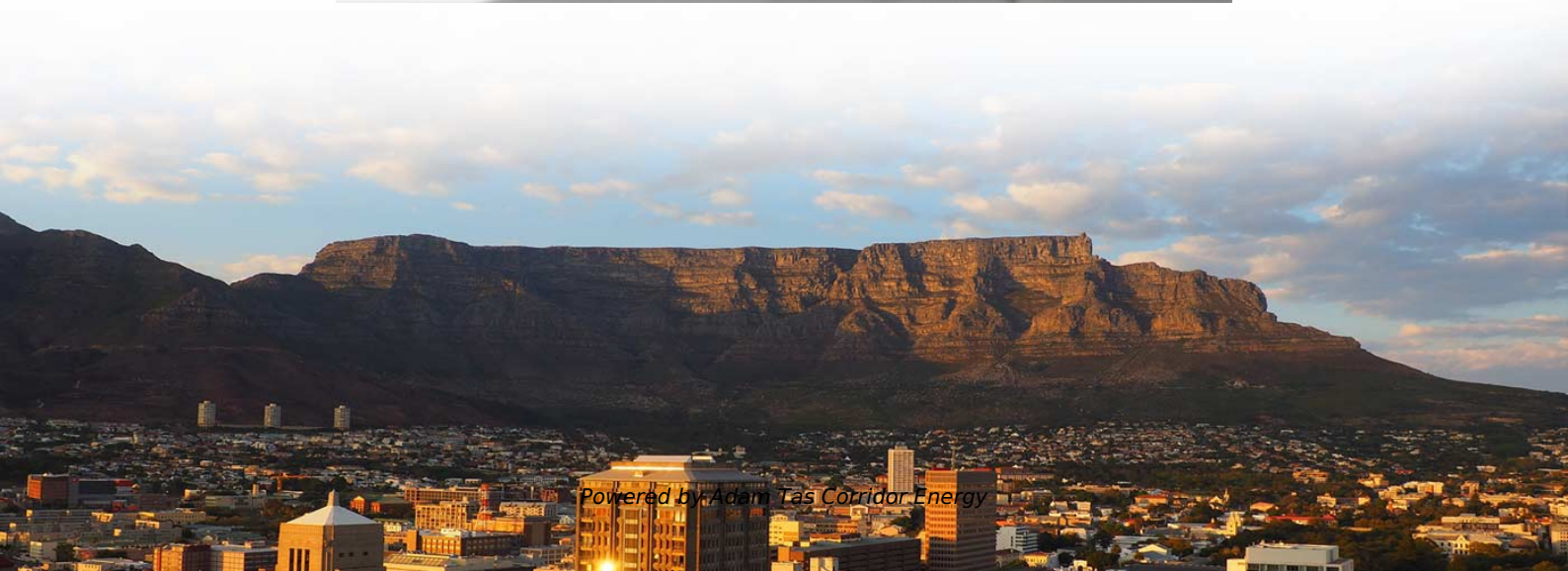

Adam Tas Corridor Energy

Method for splicing and fusion of vibration optical cables





Overview

It describes three main splicing methods - de-matable connectors, mechanical splices, and fusion splices. Splicing is typically required during cable installation, maintenance, or network expansion. Fusion splicing is the process of fusing or welding two fibers together usually by an electric arc. Splicing VHO (mechanical, fusion and ribbon) Download and use the appropriate VHO for the splices you make in your exercises.



Method for splicing and fusion of vibration optical cables



Fusion Splicing: What's and How's Answered? , Versitron

Despite being a popular method of fiber optic cable termination, Fiber Optic Splicing still remains a mystery for a large section of people. This process

Fiber Optic Cable Splicing Methods: A Practical Guide

While this guide provides a solid overview of fiber optic cable splicing, the successful execution of these methods requires extensive training, hands-on experience, and a significant

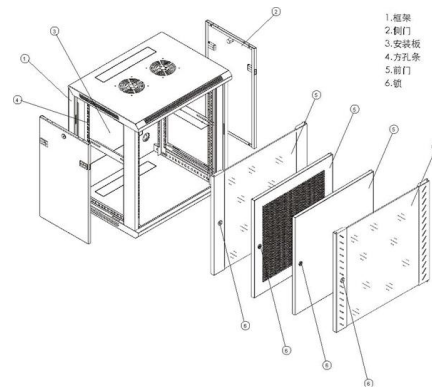

Splicing of Optical Fibers & Their Techniques

The splicing of optical fibers is one of the techniques used to join two optical fiber cables for permanent connection. This technique is also known as termination or connectorization. This



Fusion Splicing vs. Mechanical Splicing for Optical Fiber

In addition, fusion splicer devices have been designed for the field technician applications, smaller in size and easier to carry. Takeaway

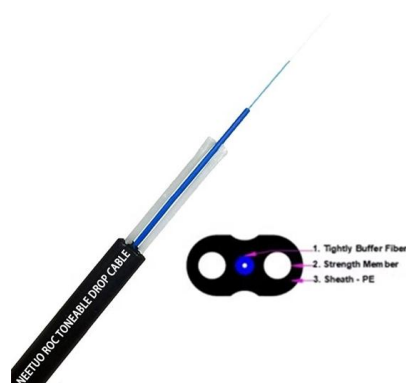

The Complete Step-by-Step Guide to Fiber Optic Splicing

As of now, fiber optic splicing can be carried out using one of two methods -- fusion splicing and mechanical splicing. Before you move forward with your fiber optic



Mastering the Art of Splicing Fiber Optic Cables: Expert

Master the essential skill of splicing fiber optic cables with our expert guide. Learn the fusion splice technique for seamless data transmission and

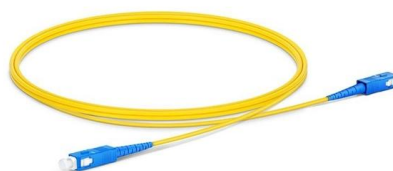

An Overview of Splicing Techniques: Pros and Cons of

In this blog, we'll explore the main types of fiber optic splicing techniques, their advantages, limitations, and how to decide which method best





Fiber Optic Cable Splicing Explained

Splicing in optical fiber is the joining two fiber optic cables together. There are 2 methods of cable splicing, mechanical or fusion.



How to Splice Fiber Optic Cable - Step-by-Step Fusion

Learn how to splice fiber optic cable using fusion splicing with this complete step-by-step guide. Includes tools, best practices, loss standards (ITU-T

Fiber Optic Cable - Method of Joining and Fusion Splicing

Learn about the fiber optic cable operating principle, types, connectors, method of joining and fusion splicing.



Fiber U Basic Skills Lab Workbook-splicing

Fusion splicing uses a machine to "weld" fibers together in an electric arc. Mechanical fibers clamp two fibers into alignment with index matching gel between them to reduce loss and reflectance.



The FOA Reference For Fiber Optics

Fusion Splicing Fusion splicing is the process of fusing or welding two fibers together usually by an electric arc. Fusion splicing is the most widely used method of



Fiber Optic Splicing

Mechanical splicing, with its higher insertion loss, is more suitable for shorter cable runs where signal integrity is less of a concern. Conclusion

Fibre Optic Cable Splicing Guide: Techniques and Equipment

Whether you're performing fusion splicing or mechanical splicing, having the right techniques and equipment at your disposal is crucial for achieving seamless and durable





The FOA Reference For Fiber Optics

Fusion splicing is the most widely used method of splicing as it provides for the lowest loss and least reflectance, as well as providing the strongest and most reliable joint between two fibers. Virtually all

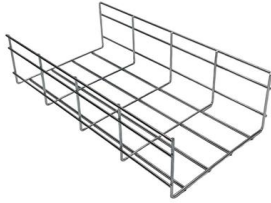

Standard Optical Fiber Fusion Splice 10 Steps And Operations

Fiber optic cable fusion splice is an important process with the largest amount of engineering and the most complex technical requirements in the optical fiber transmission system.



Motor protection controller



Mass Fusion Splicing of Optical Fiber Ribbon Cables

Ribbon cable can be spliced more rapidly by using mass fusion splicing technique. This application note provides basic understanding and process of mass fusion splicing of optical fiber ribbons.

What Is Fiber Optic Cable Splicing? A Beginner's Guide

Fiber optic splicing is often the preferred way to connect two fiber optic cables because it has lower light loss (attenuation) and back reflection than



Fiber Optic Cable Splicing Methods: A Practical Guide

Learn fiber optic cable splicing methods: fusion splice techniques and more. A practical guide to optic cable splicing for reliable fiber optics.

Fiber Optic Splicing Types, Methods, and Applications

Fiber optic splicing is essential for building and maintaining reliable, high-speed communication networks. By understanding its types, methods, and real-world

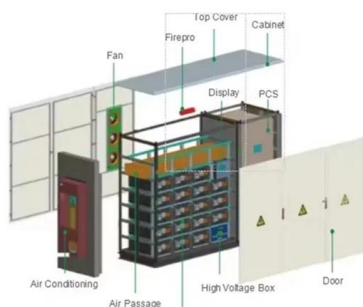
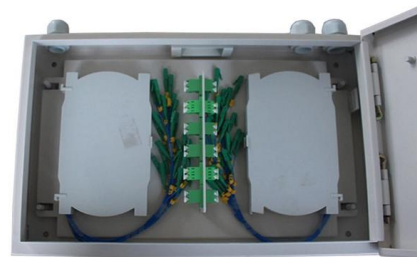

Splicing Fiber Optic Cables , A Beginner's Guide

Fusion splicing is also the most reliable method for single-mode fibers. Different from multimode fibers, single-mode fibers have a thin core that transmits signals without touching the fiber's edges. Since



Mass Fusion Splicing of Optical Fiber Ribbon Cables

Abstract To build a fiber optic network, one may eventually join two fiber ends with a connector or fusion splicer. Ribbon cable can be spliced more rapidly by using mass fusion splicing technique. This



Splicing of optical fiber , PDF

The document outlines intrinsic and extrinsic factors that contribute to splice loss and describes the fiber preparation, alignment, and fusion steps for fusion splicing.

Fibre Optic Cable Fusion Splicing Tutorial: Techniques

Mastering fusion splicing is essential for achieving reliable and efficient fibre optic cable connections in network installations. By understanding

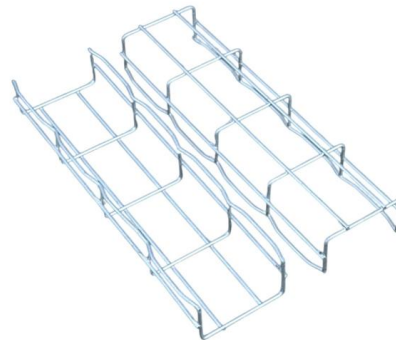

ITU-T Rec. L.12 (05/2000) Optical fibre joints

Different methods exist to obtain a fusion splice of fibres or ribbons. At the moment, electric arc-fusion is the most widely used method to make reliable single or mass optical splices in the field.



Fiber Optic Fusion Splicing Guide: From Safety to Troubleshooting

Learn Fiber Optic Fusion Splicing: step-by-step guide to safe, precise fiber prep, fusion, and testing for low-loss, high-quality

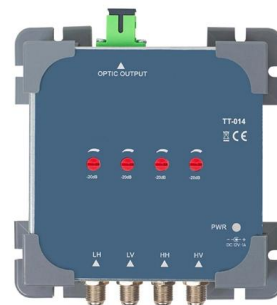

Fiber Optic Splicing Techniques Guide

The document outlines the methodology for fiber optic splicing, detailing both fusion and mechanical splicing techniques. Key steps include preparation of the fibers,

Fibre Splicing Explained: A Complete Guide to

Learn how fibre splicing works, including fusion and mechanical methods, and discover how it enables reliable, low-loss optical fibre connections





A Complete Guide for Fiber Optic Splicing

Fiber splicing is to connect two optical cables together. Another more common method of joining fibers is called termination or joining.

Contact Us

For datasheets, pricing, or custom telecom energy solutions, please visit:
<https://koskolong.co.za>