

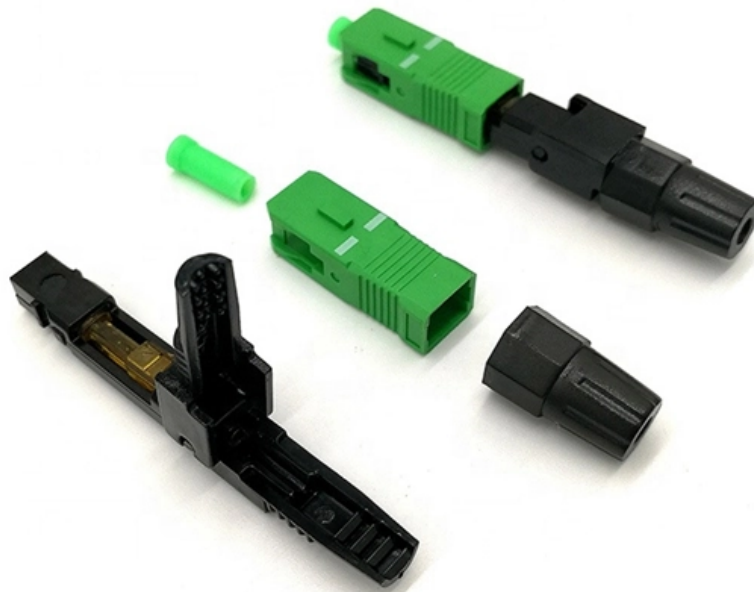

Adam Tas Corridor Energy

Optical cable twisting angle





Optical cable twisting angle



Fiber Optic Cable Bend Radius: What Is It & Why It Matters

Worried about damaging fiber optic cables during installation? Learn how to calculate fiber optic cable bend radius to protect your network.

Experimental Approach for Complex Optical Fiber Angular Orientation

The presented method for orientation angle measurement is based on analyzing a diffractive-refractive scattering pattern of complex optical multicore bers illuminated from the side fi by a laser source.



Fiber-Optic Cable Signal Loss, Attenuation, and Dispersion , Juniper

Attenuation and Dispersion in Fiber-Optic Cable
Correct functioning of an optical data link depends on modulated light reaching the receiver with enough power to be demodulated correctly. Attenuation is



8.1: Optical Fiber

Example 8 1 1: Critical angle for optical fiber
Typical values of n_f and n_c for an optical fiber are 1.52 and 1.49, respectively. What internal



angle of incidence is



50km/spool



Can You Bend Fiber Optic Cable? A Guide to Safe

Fiber optic cables have revolutionized communication networks, providing extremely fast data transmission through pulses of light traveling along

Analysis of Longitudinal Stress Imparted to Fibers in Twisting an

Just prior to sheathing, the unit is twisted to a given period (lay) in order to improve its bending properties. Moreover, good cable bending properties dictate short lay lengths.



Fiber Cable Bend Radius Engineering Limits and

Engineering guide to cable bend radius limits, including static and dynamic requirements based on IEC, TIA, and fiber cable construction.



Cable stranding has two ways: SZ twisting and helical

Cable stranding has two ways: SZ twisting and helical twisting. Helical twisting means that all conductors are twisted in one direction, and the angle of



How to twist and turn a fiber: Performance modeling for optimal DAS

AS system measures strain (e.g., Parker et al., 2014) along a fiber-optic cable. The fiber can have lengths of 10 km or more, and measurements can be taken at near-continuous intervals,

The FOA Reference For Fiber Optics- Installing Fiber

General Guidelines For Installing Fiber Optic Cable Fiber optic cable may be installed indoors or outdoors using several different installation processes.



Fiber Bending Radius: Key to Signal Performance

When it comes to fiber optic cables, one of the most critical factors for ensuring reliable performance in fiber optic technology is understanding the



Considerations for Improved Bend Performance Optical Fibers

While IBP fibers can be used in virtually any cable design, they measurably improve system performance only where fibers or light-duty cables will be or might be acutely bent.



A Brief Guide to Fiber Optic Bend Radius

When you deploy fiber optic cable, it is inevitable to bend the cable. It is necessary to consider the fiber optic bend radius to ensure successful

Effects of bending on fiber optic cables

Cable bending during installation and after installation are the two major mechanical parameters for the optical fiber cable, that is often asked by customers to quote. Strictly following the installation





Basic Principles of Fiber Optics Series: Refraction

This article examines the principle of refraction and how it applies to fiber optics. Learn what causes refraction, how to calculate an index, and how

Cable stranding has two ways: SZ twisting and helical

Helical twisting means that all conductors are twisted in one direction, and the angle of twist along the axial direction of the optical cable is constant.



Still Worried About Bend Radius? Come and See the

FTTx networks are the impetus for the adoption of fiber cables. During installation of these cables, more attention is focused on the effects of

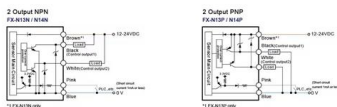

Cable Twist-Bend - Fiber Optic Cable

The cable may be subjected to simultaneous twisting and bending forces at specific angles or radii, depending on the desired testing conditions. Performance Evaluation: Assess the cable's



Effect of fiber twist angle and non-uniform symmetric

Overall, a twist angle between 10° and 70° maintains both high transmission efficiency and good beam quality. The twist angle and non-uniform



Optical Cable Torsion Testing Machine

UNIVER CTR-1000 Series Fiber Optic Cable Torsion/Twist Testing Machine is designed to evaluate the ability of optical fiber cables to withstand mechanical



Twisting measurement and compensation of optical shape sensor

Fiber Optic Shape Sensors (FOSS) consist of optical Multicore Fibers (MCF) (or sometimes multi-fiber cables, with the same section geometry but larger core spacing) capable of





Fiber-Optic Sensors for Measurements of Torsion, Twist and Rotation:

Measurements of twist/rotation have, thus, recently been topics of intense research within the fiber-optic sensor community. Furthermore, many applications in rotation/twist/torsion sensing cannot tolerate



Fiber-Optic Sensors for Measurements of Torsion, Twist

Optical measurement of mechanical parameters is gaining significant commercial interest in different industry sectors. Torsion, twist and rotation are

Manage Bend-radius in Cables » SENKO Advanced

Angled adapters are engineered to reduce cable congestion and maintain efficient routing in spaces where direct connections may not be feasible. They allow



Analysis of Longitudinal Stress Imparted to Fibers in Twisting an

In the exploratory Fiber Optic (FO) cables used in the Atlanta Fiberguide System Experiment, 12 optical fiber ribbons each containing 12 fibers are stacked one on top of the other to form a rectangular array

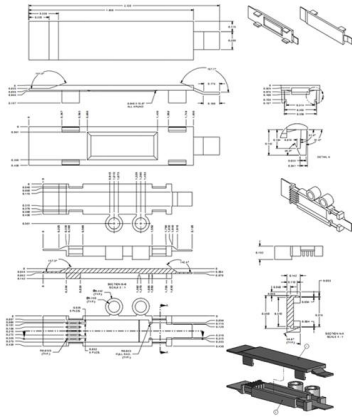

Twisting Effects on Fiber Optic Cables Explained

In this article, you will learn how twisting impacts fiber optic cables and how to prevent or minimize its effects.



Top 10 Fiber Optic Mistakes to Avoid , trueCABLE

Avoid costly fiber optic installation errors. Learn the top 10 things NOT to do with fiber optic cables and how to handle them safely.

Analysis of longitudinal stress imparted to fibers in twisting an

In the exploratory fiber optic cables used in the Atlanta Fiberguide System Experiment, 12 optical fiber ribbons each containing 12 fibers are stacked one on top of the other to form a rectangular array of





Contact Us

For datasheets, pricing, or custom telecom energy solutions, please visit:
<https://koskolong.co.za>