



Power distribution boxes and equipment distribution boxes

OEM/ODM
CUSTOMIZATION AVAILABLE



Full product customization



Structure customization



Brand customization

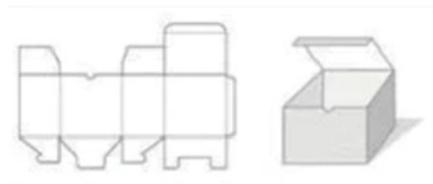

Packaging design





Power distribution boxes and equipment distribution boxes



Choosing the right power distribution box solution for your needs

Different power distribution boxes come with varying configurations, including standard electrical outlets, twist-lock receptacles, or a combination of both. The power distro box that you choose will need to

Understanding Distribution Boxes: A Comprehensive Guide

Learn what a distribution box is, its types, and how to choose the right one for your project. Includes clear examples and expert tips.

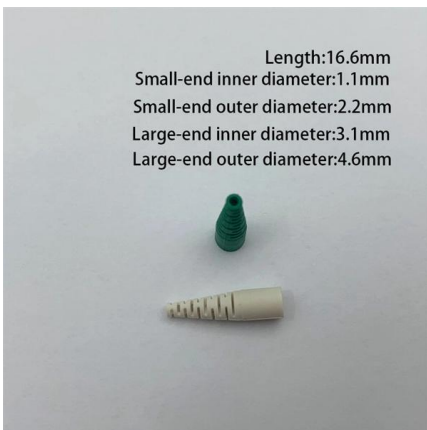

The Ultimate Guide to Distribution Box Types

In any electrical system, the distribution box is the heart and brain, a critical component that safely manages and distributes power from the main source to

Explore Power Distribution Box Types and Functions

In the distribution box, commonly known as the distribution board or breaker panel, you'll find several critical components responsible for



What is the Internal Structure of The Distribution Box

What is a Distribution Box? Definition A distribution box is an essential electrical component used to manage and control the flow of electricity



Power Distribution Box Essentials: Functions, Types

Easy distribution via Power distribution box + Longer Lifespan of Equipment: Electrical appliances and machines are made to last longer due to



What Is an Electrical Distribution Box? A Complete Guide

What Is an Electrical Distribution Box? An electrical distribution box serves as a centralized unit for distributing electrical power within





Custom Power Distribution Box Manufacturers , J& HW

We deliver tailored solutions for electrical power distribution boxes and distribution electrical boxes, avoiding unnecessary features and ensuring a perfect fit for your



A Definitive Guide To Distribution Boxes

The distribution box acts as the center of power distribution, distributing electricity to all connected devices. A distribution box, also known as a distribution board, panel board, breaker



Power distribution boxes - safe site power distribution , Modipro

Browse our selection of power distribution boxes below and choose the right unit to match your project requirements, power demands and safety criteria. Power distribution boxes for safe and flexible



Distribution Box Guide: Types, Components & Solutions

Understand distribution boxes (DB boxes) in 5 minutes. Learn about types, components, functions, and uses. Find the perfect DB box for your needs.



Professional Power Distribution Units PDU , DISTRO

mobile distribution boxes Users in over 68 countries worldwide appreciate the ruggedness, dependability, design and lifespan of our power distribution boxes.



How Does a Power Distribution Box Work

Learn how a power distribution box works step by step--from incoming power to circuit protection and smart monitoring--for safe, efficient electricity delivery.

Distribution Boxes

Discover E-Abel's wide range of durable distribution boxes for industrial and electrical use, offering practical, flexible, and innovative solutions.

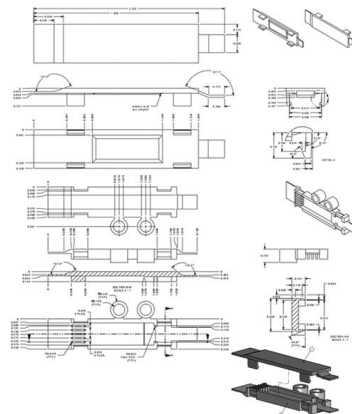

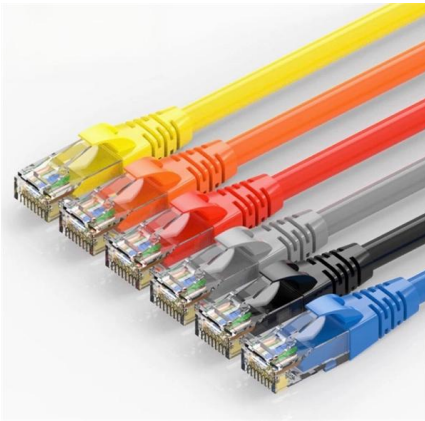

What is a Distribution Box? - A Comprehensive Guide

A distribution box organizes and controls power flow, ensuring safety and efficiency in electrical systems.

Distribution Boxes Explained: Types, Functions, and

Learn about distribution boxes, their types, functions, and safety features to ensure efficient and secure electrical power distribution in any building.



Power Distribution Equipment

Each has its own unique standards and application guidelines, and one facet of good power system design is the knowledge of when to apply each type of equipment and the limitations of each type of

The Complete Guide to Distribution Box: Installation, Types & More

Smart distribution boxes integrate digital monitoring and control systems that provide real-time information about electrical consumption, power quality, and equipment status.





How does a power distribution box work

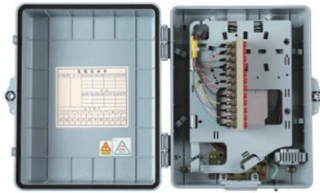

The distribution box is a very important component of the power system. It is responsible for transmitting electrical energy from the power station

Ultimate Guide To Distribution Boxes Db Boxes Types

This ultimate guide explains what a distribution box does, its internal components, common types, real-world applications, and how to select the right DB Box for



Understanding Power Distribution Boxes: Types, Features, and

This guide delves into the intricacies of power distribution boxes, shedding light on their design, functionality, and regulatory standards. Readers can expect to gain a comprehensive

12 types of distribution boxes and how to choose them

In this guide, we'll break down the 12 main types of distribution boxes in a way that's easy to understand. We'll chat about what each one does, where it shines, and then dive into how to choose the perfect



Complete Guide For Distribution Boxes Types

Distribution boxes, also known as electrical distribution boards or panels, are pivotal components in electrical systems, ensuring the safe and organized distribution of



Understanding Outdoor Power Distribution Box: A

Explore the features and benefits of SX outdoor power distribution box, designed for durability, safety, and reliable power in any environment.



Contact Us

For datasheets, pricing, or custom telecom energy solutions, please visit:
<https://koskolong.co.za>