



Adam Tas Corridor Energy

Price of circuit for a 3-room distribution box





Overview

On average, homeowners invest between \$570 and \$1,000 for the cost to install a dedicated circuit, with most paying an average of \$700. Various factors influence the final price, including the type of circuit needed, the complexity of installation, and your geographic. Understanding distribution box cost involves examining the comprehensive investment required for electrical distribution systems that serve as crucial infrastructure components in residential, commercial, and industrial settings. The surface-mounted damp room distributor is made of high-quality acrylester-stirene-acrylonitrile (ASA) and is therefore more weather-resistant than conventional ABS. Example: Need a circuit for your 1,800W microwave?

Calculator Tip: Tools like Desmos' scientific calculator make light work of conversions. You're not just calculating numbers—you're designing a system that matches how you live.



Price of circuit for a 3-room distribution box



The Ultimate Guide to Distribution Box Types

In any electrical system, the distribution box is the heart and brain, a critical component that safely manages and distributes power from the main source to

How to Choose the Right Distribution Box?

5. Should I consider future expansion when choosing a distribution box? Yes, it's wise to choose the right distribution box with room for future circuit



Electrical Distribution Panel Guide: Types, Sizing & 600

From residential 100-amp panels to massive 600 amp main distribution panels in commercial facilities, this comprehensive guide will help you

Industrial 3 Phase Electrical Distribution Box Guide

Explore the essentials of industrial 3 Phase Electrical Distribution Box for efficient power



management in commercial settings. Get expert insights now.

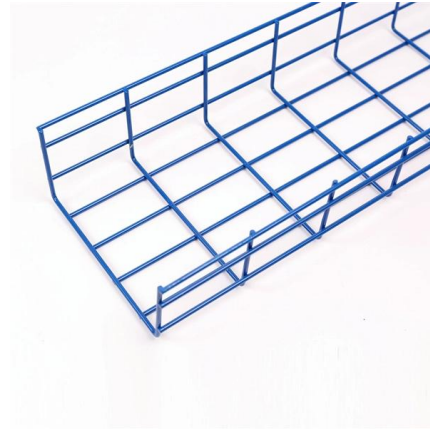

Distribution Box Price in Pakistan , Clopal Electric

Distribution Boxes Price In Pakistan If you are a commercial or residential property owner, you need to cover hundreds of electrical wires. Cable management is not

Distribution Box Cost Guide 2024: Comprehensive Pricing, Features

The distribution box cost varies significantly based on specifications such as voltage ratings, amperage capacity, number of circuits, material construction, and integrated safety features. Standard

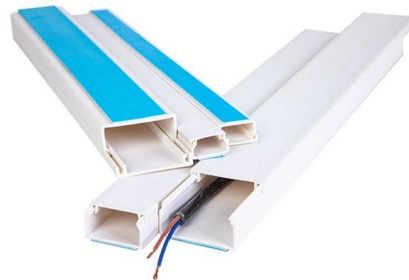

The Complete Guide to Distribution Box: Installation, Types & More

The primary purpose of a distribution box is to provide a safe and organized way to control electrical circuits. When an electrical fault occurs, such as an overload or short circuit, the protective



cs-178-project/imdb.vocab at main · apmalani/cs-178-project

Contribute to apmalani/cs-178-project development by creating an account on GitHub.



Step-by-Step Guide to Wiring a 3 Phase DB Box

Learn about the wiring process for a 3 phase distribution board (DB) box, including the necessary steps and safety precautions. Understand how to connect the



Size configuration of multiple circuit breakers in the

Choose the right size and setup for multiple circuit breakers in your distribution box to ensure safety, code compliance, and room for future upgrades.



how to calculate cost of distribution box

Please provide specific requirements, ezitown will calculate the best price for you. Share This Story, Choose Your Platform!



Distribution Box

Find here Distribution Box, Distribution Box for Home manufacturers, suppliers & exporters in India. Get contact details & address of companies



Wet room distribution box, 3-row, 36 modules

Depending on the housing type, different metric pre-stamping is available, often 2 different sizes can be broken out depending on the requirements. The requirements of the DISBOX-F series are an



What is a DB Box? Types, Wiring, Selection Guide

What is a DB Box In the world of electrical installations, the term DB box --short for Distribution Board box --refers to the central unit that distributes incoming





Distribution Box Replacement Cost Guide 2026



Overview Of Costs Cost ranges account for panel amperage, location, and whether a full upgrade or repair is needed. A typical home replacement for a 100-125A indoor panel runs about

Busbar

Distribution boards split the electrical supply into separate circuits at one location. Busways, or bus ducts, are long busbars with protective covers. Rather than



Distribution Box Cost Guide 2024: Comprehensive Pricing, Features

Discover complete distribution box cost analysis including pricing factors, advanced features, safety benefits, and smart technology innovations. Get expert insights on ROI, installation costs, and long

How to Calculate the Size and Number of Circuits for a Distribution

Okay, let's talk distribution boxes. You know that metal cabinet packed with switches and wires you see in basements? Yeah, that's the heart of your electrical system. Getting its sizing right isn't just about



WORLD WIDE WEB JOURNAL Home

Capturing the state of distributed systems with XML Rohit Khare, Adam Rifkin November 1997pp 207-217 article

Distribution Box and Selection Guide

Different settings have distinct electrical requirements: Residential: Homes typically require single-phase power and a Distribution Box with fewer



Power Distribution Panels , McMaster-Carr

Choose from our selection of power distribution panels, including square D circuit breaker boxes, electrical wiring and connecting, and more. Same and Next Day Delivery.



How to Choose a House Distribution Box , CHINT

An optimal distribution box configuration ensures efficient power management and safety. The recommended configuration is: 1 Main Switch:

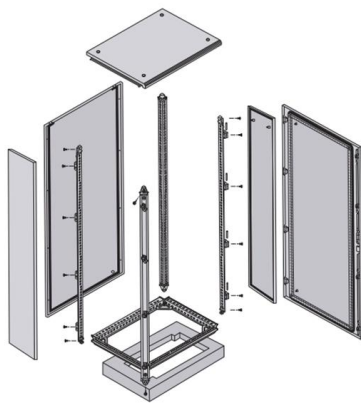

How Much Does Dedicated Circuit Installation Cost? [2025 Data]

Use this guide to estimate the cost to install a dedicated circuit based on factors like circuit type, labor, materials, location, and installation complexity.

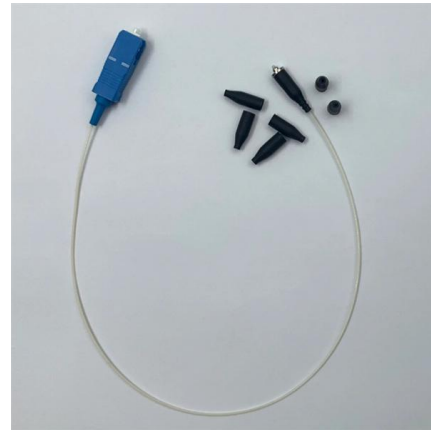

Distribution Boards

Distribution boards, often referred to as electrical panels or breaker boxes, serve as the nerve center of any electrical system. Here we explore the crucial parts of a distribution board and gain insights into



Electrical Distribution Box Design Guide

The document provides details for designing the electrical distribution box and circuits for a residence. It includes specifications for the main circuit breaker such



Wet room distribution box, 3-row, 36 modules

Wet room distribution box, 3-row, 36 modules
Wet room distributors by BOXEXPERT - Reliable
delivery favourable prices For business and
private Order online at reichelt elektronik now!



Contact Us

For datasheets, pricing, or custom telecom energy solutions, please visit:
<https://koskolong.co.za>