

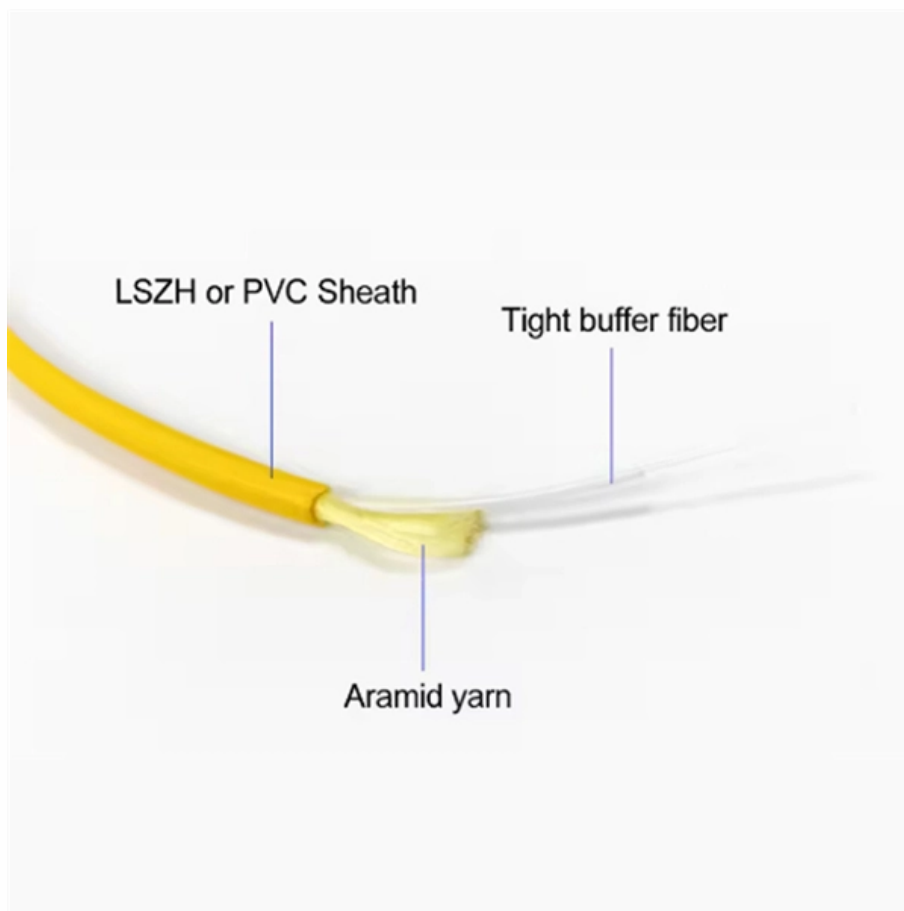

Principles and Relay Protection





Principles and Relay Protection



Relaying and System Protection for Electric Utilities Volume I

Preface This course is one of a series of five courses on the design of relaying and system protection programs for electric utilities. These courses describe the fundamental concepts of electric system

Power System Protective Relays: Principles & Practices

This presentation reviews the established principles and the advanced aspects of the selection and application of protective relays in the overall protection system, multifunctional numerical devices



Power System Protective Relays: Principles & Practices

Abstract: Protective relays and devices have been developed over 100 years ago to provide "last line" of defense for the electrical systems. They are intended to quickly identify a fault and isolate it so the



Basic protection relay knowledge

Protection is needed to detect electrical faults and abnormal operating conditions. Protection is also needed for protecting people and property



around the power network. The protected zone is the part



Basics of Protective Relaying and Design Principles

In this section the principle of the overcurrent relay operation is discussed. The following issues are explained and covered by the MATLAB models and related simulations: Rules for protecting a

Basic Theories of Power System Relay Protection

This chapter first introduces the basic theories of power system relay protection, summarizes the functions and basic requirements of relay protection, and illustrates the basic principles of relay

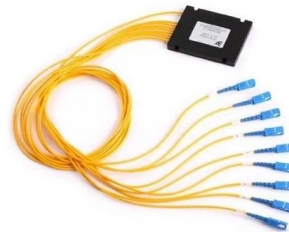

Basic Principles of Relay Protection

Basic Principles of Relay Protection Relay protection is a vital aspect of electrical power systems that ensures the safety and integrity of the network,



Principles and Characteristics of Distance Protection

Principles of Distance Relays Since the impedance of a transmission line is proportional to its length, for distance measurement it is appropriate to use



Instagram

122 likes, 0 comments - theelectricaladda on May 8, 2026: " Basic overview of electrical relays
1. Introduction to Electrical Relays - A relay is a protective device used to detect faults and isolate faulty

Protective Relay Principles

Protective Relay Principles by Anthony M. Sleva delves into the essential concepts of protective relaying for electrical power systems. Ideal for engineers and students, this used book in good condition



Practical handbook for relay protection engineers , EEP

Also principles of various protective relays and schemes including



Protective Relaying

Protective relaying, commonly abbreviated as relaying, is a nonrevenue-producing item that is not necessary in the normal operation of an electrical power system until a fault--an abnormal,

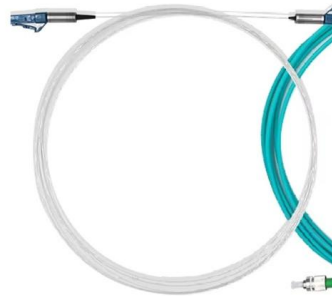

OPEN DELTA PT for protection applications and how to

Protection relays has evolved from magnetic beam based electro-magnetic principles to modern digitized Intelligent devices which are multi

Protective Relaying Principles and Applications

Protective Relaying Principles and Applications
The article provides an overview of protective relaying principles and their applications for high-voltage power system





SIEMENS_RELAYS_RASHAD_AWAD.pdf , Mohamed Samak

Stanley H. Horowitz And Arun G. Phadke
<https://lnkd/dAbkU4r4> - Protective Relaying Principles And Applications, 4th Edition
<https://lnkd/dncxhF8c> - Numerical Distance Protection Principles

Protective relay

Distance relays, also known as impedance relay, differ in principle from other forms of protection in that their performance is not governed by the magnitude of the



Protective Relaying: Principles and Applications, Third Edition

Thoroughly updated and revised, this third edition focuses on technological changes in the design of protective systems, the practical concerns of power system protection encountered by

Relay: How Electromechanical Switching Works and Types

Learn how relays work, their types, characteristics, and applications in automation, protection circuits, and remote switching.



Basics of Protective Relaying and Design Principles

Perform power system simulations of selected faults and observe how a given protection principle (overcurrent, impedance, and differential) works. Set the relays for a given power system. Verify by



Protective Relay: Working, Types, and Applications

Learn about protective relays, their working principle, types, and applications in power systems. Discover how relays protect transformers,



44 Protective Relay Manufacturers in 2026

44 Protective Relay Manufacturers in 2026 This section provides an overview for protective relays as well as their applications and principles. Also, please take a





Relays , Power System Protection 1: Principles and components

A protective relay is a relay which responds to abnormal conditions in an electrical power system, to control a circuit-breaker so as to isolate the faulty section of the system, with the minimum

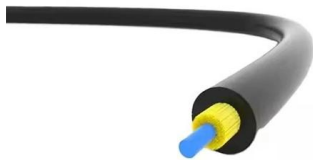

Protective Relay Principles

Protective Relay Principles focuses on probable power system failure modes and the important characteristics of the protective relays used to detect

What is a Protective Relay? Principle, Advantages,

Protective Relay Principle A protective relay is an electrical component that is designed to trip a circuit breaker when a fault is encountered or



Protective Relaying

The protective relays act only after an abnormal or intolerable condition has occurred, with sufficient indication to permit their operation.



Transformer: What is it? (Definition And Working Principle)

Key learnings: Transformer Definition: A transformer is a passive device that transfers electrical energy from one circuit to another using

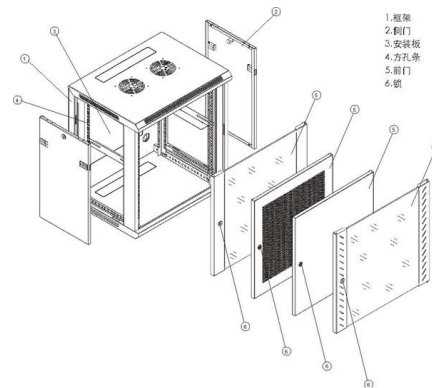

Protective Relaying Principles and Applications

The article provides an overview of protective relaying principles and their applications for high-voltage power system components. It covers the protection



Introduction to Protective Relaying , Electric Power

Introduction to Protective Relaying What are Protective Relays, or Protection Relays? Protective relays are used in industrial power generation and supply





Contact Us

For datasheets, pricing, or custom telecom energy solutions, please visit:
<https://koskolong.co.za>