



Adam Tas Corridor Energy

Rack-mounted lithium battery cabinet 100kWh commissioning





Rack-mounted lithium battery cabinet 100kWh commissioning



100KW 232KWh Industrial And Commercial Energy Storage Cabinet

PRODUCT INTRODUCTION 100kw 232 kwh battery storage cabinet integrates energy storage batteries, PCS modules, EMS, 3-level battery management system, photovoltaic modules, distribution

LiFePO4 Server Rack Battery Series

48V Server Rack Battery LiFePO4 Rack Mounted Cabinet Battery PKENERGY provides server rack battery assembly services. The finished products are ready

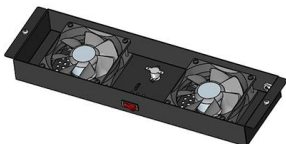
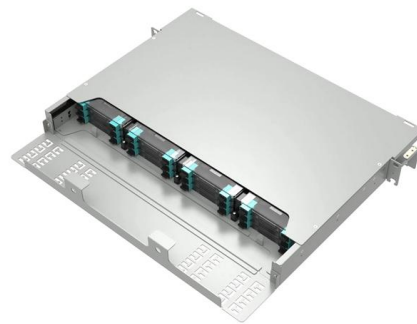

Buy Felicity Solar 40.96kWh HV Battery System , Solar Storage Europe

Buy the Felicity Solar 40.96kWh high-voltage LiFePO4 battery system with 409.6V nominal voltage, IP21 rack mounting, CAN/RS485 and BMS for commercial solar energy storage in Europe.

Customize Size Solar Battery Rack Cabinet for 51.2v 100ah LifePO4

Key attributes Battery Type LiFePO4 System Voltage 51.2 V Output Power Range 5-10kW Grid



connection Off grid, Hybrid grid Type Split System Type Rack-mounted Communication Port CAN,



Deye 10kwh Battery SE-G10.2 LFP Battery 51.2V 200Ah Deye 10.24KWH Rack

Eco-Friendly Construction: The SE-G10.2 is built with environmentally protective materials, ensuring that the entire module is non-toxic and pollution-free. Versatile Mounting Options: This battery can be

Commissioning tests of 100kWh battery energy storage system for a

Grid-connected battery energy storage systems with fast acting control are a key technology for improving power network stability and increasing the penetration of renewable



100KW 215KWh Industrial And Commercial Energy

PRODUCT INTRODUCTION 100kw 215 kwh battery storage cabinet integrates energy storage batteries, PCS modules,EMS,3-level battery management





Revolutionizing Energy Storage: TLS Energy's

TLS Energy's 100kW/233kWh all-in-one energy storage cabinet is a high-performance solution for industrial and commercial applications. With



100KW 232KWh Industrial And Commercial Energy Storage Cabinet

It is an one-stop integration system and consist of battery module, PCS, PV controller (MPPT)(optional), control system, fire control system, temperature control system and monitoring system.



100KWh HV Lithium Battery Rack

With the 100KWh HV Lithium Battery Rack, you can control



rack mounted lithium batteries cabinet 50kwh 100kwh

selection rack mounted lithium batteries more complete details about rack mounted lithium batteries cabinet 50kwh 100kwh oem suppliers or manufacturer china



- IP65/IP55 OUTDOOR CABINET
- WATERPROOF OUTDOOR CABINET
- 42U/27U
- OUTDOOR BATTERY CABINET

100kWh Commercial Energy Storage System for C& I Applications

Commercial-Grade Cabinet Design: With a floor-mounted structure, modular battery rack configuration, and scalable system design, this energy storage cabinet is suitable for flexible C& I energy storage

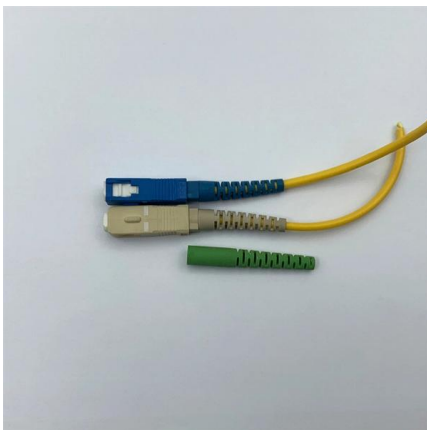
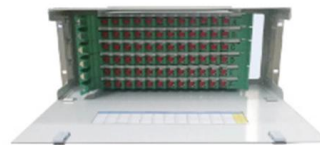

100kW 215kWh All-in-One Battery Storage Cabinet

This industrial and commercial battery storage system is the ideal compact solution for your battery projects to work alongside solar PV, EV chargers and back up power requirements.

51.2V 100Ah Rackmount Battery - 5.12kWh ESS

The 51.2V 100Ah batteries - Rackmount are high-end products custom-made for a mainly commercial and industrial clientele.





SBS-51.2V/100Ah Rack/Cabinet Mounted Lithium

The SBS- Rack/Cabinet mounted lithium energy storage battery, uses high cycle lithium iron phosphate cells, high-performance BMS protection and management

Rack Mount LiFePO₄ Batteries for Energy Storage Projects

Looking for compact, rack-mounted lithium batteries? Explore how LiFePO₄ technology powers telecom, solar, and edge systems with ACE Battery's custom modules.



5kWh Rack-Mounted LiFePO₄ Battery 51.2V 100Ah

The 5kWh rack-mounted LiFePO₄ battery (51.2V 100Ah) is engineered for solar ESS and server rack installations. With Grade A cells, advanced BMS, and long cycle

100KWH ESS Energy Battery Cabinet , AZE

AZE's lithium battery energy storage system (BESS) is a complete system design with features like high energy density, battery management, multi-level safety





50kwh 80kwh 100kw 200kwh Battery Storage All in One

Currently our best-selling products are lithium batteries 12V, 24V 50-400AH which can directly replace lead-acid batteries, and rack-mounted batteries

100kWh Rack-Mounted Commercial & Industrial Energy

The 100kWh rack-mounted C&I energy storage system provides safe, efficient, and expandable power for various commercial and industrial applications. Modular

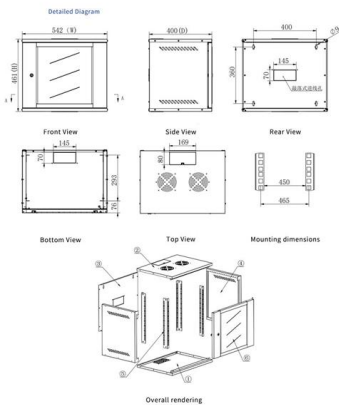
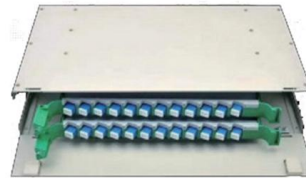

APC Symmetra LX 16kVA Scalable to 16kVA N+1 Rack-mount,

APC SYMMETRA LX 9 BATTERY Rack-Mount XR FRAME, 208V APC Symmetra LX 15-foot battery cabinet cable- 200/208V APC Symmetra RM and LX 4 Ft. extender battery cable for

Cabinet case rack mounted lifepo4 battery 51.2V 100Ah

Cabinet case rack mounted lifepo4 battery 51.2V 100Ah 5kWh for solar energy storage systems
Description Overview: MOTOMA M series LiFePO4 battery



100KWh Rack mounted battery cabinet_on BuildMost

Compatible with most hybrid/battery inverter in selfconsumption, back-up and off-grid applications.



EG4-LL Rack Mounted Battery Manual

EG4-LL Rack-Mounted lithium battery products are suitable for low-voltage small and medium-sized energy storage system applications. These products adopt the highest safety performance lithium



BLOO POWER , 50kwh 100kwh 200kwh High Voltage Rack Mounted Lithium

Zhengde Hanyuan (Shenzhen) Technology Co., Ltd. (Bloo Power) Solar Storage System Series 50kwh 100kwh 200kwh High Voltage Rack Mounted Lithium Battery. Detailed profile including pictures and



100KW Lithium Ion Battery Storage Cabinets

Configured with a rack-mounted modular PCS, it supports parallel connection of multiple machines and has good scalability; the number of PCS modules and the



High Voltage Industrial Rack Lithium Battery 100kWh

High Voltage Industrial Rack Lithium Battery 100kWh 200kWh 215kWh Cluster RACK HV PRO is a high-performance embedded LiFePO4 battery module,

Buy Felicity Solar 61.44kWh HV Battery System , Solar Storage Europe

The Felicity Solar 61.44kWh High-Voltage LiFePO4 Battery System is a rack-mounted commercial energy storage solution for professional solar PV projects. Built with 12 x 5.12kWh LiFePO4 battery

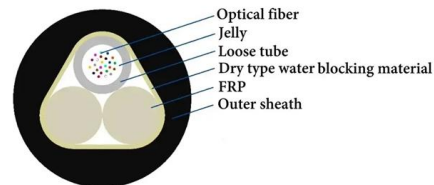

Contact Us

For datasheets, pricing, or custom telecom energy solutions, please visit:
<https://koskolong.co.za>