

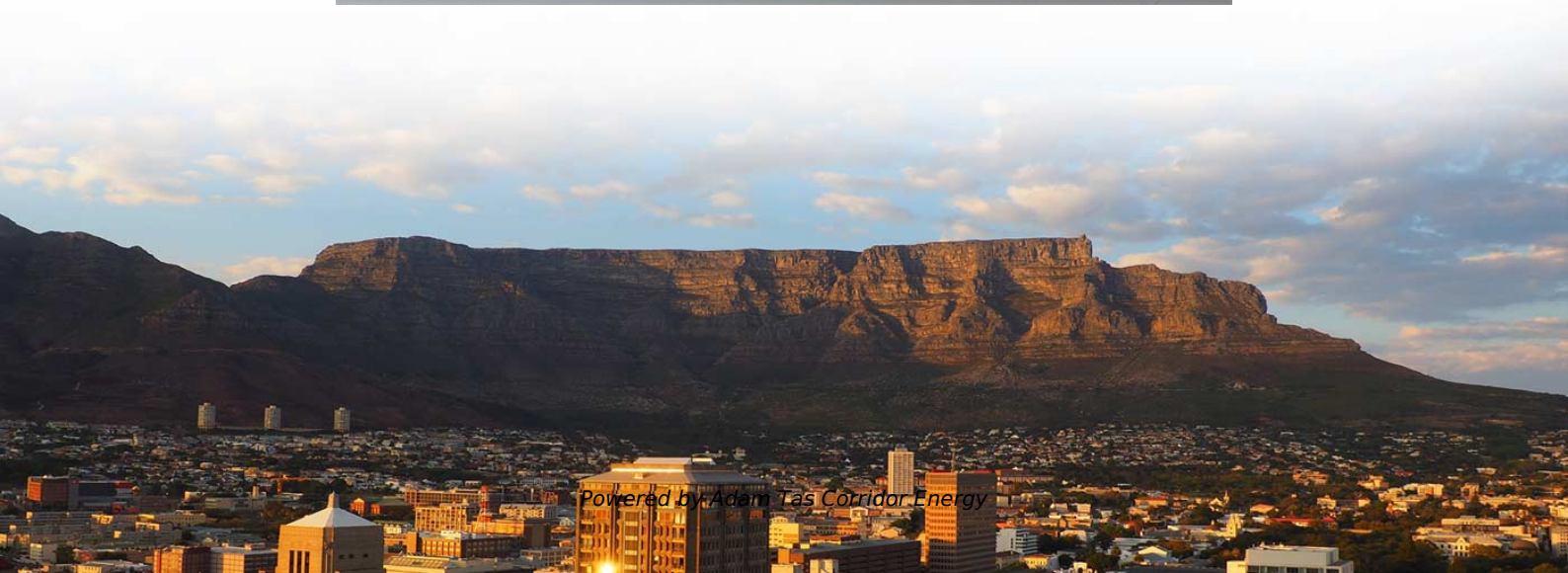

**Adam Tas Corridor Energy**

# **Ranking of Polish Fire Cable Trays**





## Ranking of Polish Fire Cable Trays

---



### Cable trays and ducts

We offer products of the following Polish brands: KOPOS, STASIŃSKI, LEGRAND, BAKS, EL-PUK. The brands are famous for their high quality products for laying cable paths.

### Fire Rated Cable Tray, Heavy-Duty Cable Tray Manufacturer

Fire Rated Cable Trays that are crafted from premium materials like stainless steel, galvanized steel, tempered glass, and fire-resistant polyester fiberglass. Each tray is coated with a specialized fire

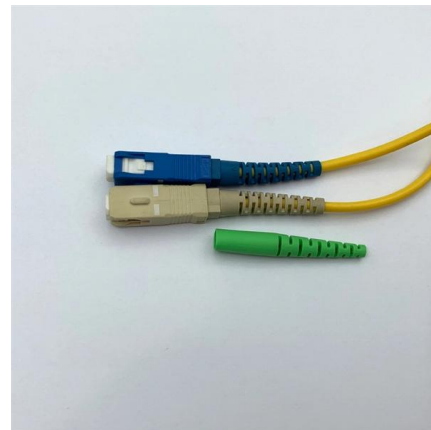

### Cable trays

Poszukujesz trwałych korytek kablowych do tworzenia kompletnych tras dla przewodów instalacyjnych? Wybierz modele z oferty firmy EL-PUK!



### Fire-Resistant Cable Support Systems

Check out detailed instructions on fire-resistant installations on our brochure [Download brochure](#)



in English: Fire resistant cable support systems  
v.5 In all fire



### **Fire Protection of Cable Trays , Ceasefire PFP**

Proper fire protection for cable trays is crucial for maintaining building safety. Find out more with our passive fire protection services.



### **FireMaster Cable Wrap F**

FireMaster Cable Wrap is approved by Factory Mutual for fire protection of grouped electrical cables according to fire testing protocols required by the American Petroleum Institute.



### **Fire-Resistant Cable Support Systems**

Meka Pro regularly tests the fire resistance of its products to ensure high-quality and safe cable management systems. The products are tested extensively and using





## Cable Trays , DACPOL Poland

In the category of cables, litz wires, conduits, flexible connections we're offering cable trays, halogen-free trays, IBOCO trays, and BETADUCT trays - pvc. High quality Noryl halogen-free trays have



## Fire-Resistant Cable Trays in High-Risk Environments

Explore the importance of fire-resistant cable trays in high-risk environments. Learn about the best materials and practices to

## Fire protection for cables & cable trays , Flamro

Fire protection for cables and cable trays: effective solutions to prevent cable fires Cable systems are found in all buildings nowadays: from industrial plants via



## Fire Rated Fire Cable Trays

Home Other Smoke & Fire Fire Cable Trays Fire Rated Fire Cable Trays Passivefire Warehouse has 1000's of products relating to both Passive Fire and Active Fire and you can find everything you need

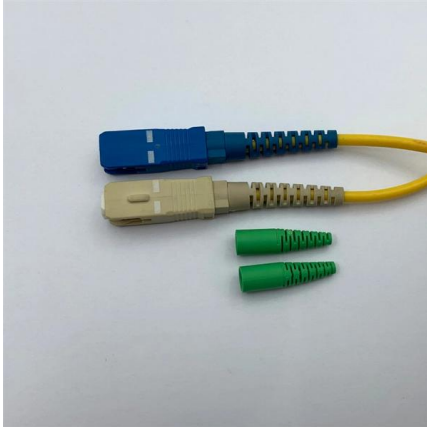

## Protecting Cable Trays Against Hydrocarbon Fire In The

Protecting Cable Trays Against Hydrocarbon Fire In The Oil & Gas Industry By Chris Dodds on 2nd March, 2015 Follow @ThorneanDerrick The

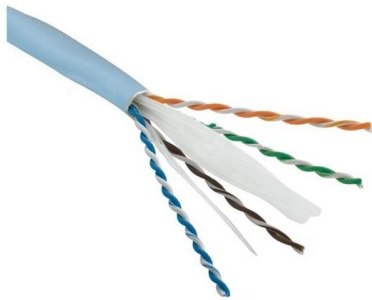

## Trunking & Cable Trays

A removable glass cloth coated pillow filled with fireproof sponge and intumescent material which expands to 3 times its original size in a fire, stopping gaps in or

## Fire Rated Cable Tray

Fire Rated Cable Tray Ozstrut Fire Rated Cable Trays provide reliable cable management with proven fire resistance, ensuring critical circuits remain



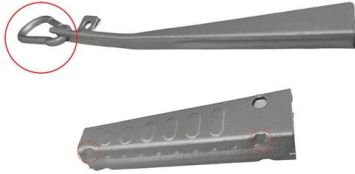

## Design Considerations for Protection of Cable Trays

The fire protection of electrical raceways or cable trays that act as conduits for cables supporting these process critical functions is therefore of vital

## Fire resistant products by Trayco , Trayco

Which is why we attach great importance to the continuous search for installation-friendly solutions capable of guaranteeing the functioning of vital electrical wiring

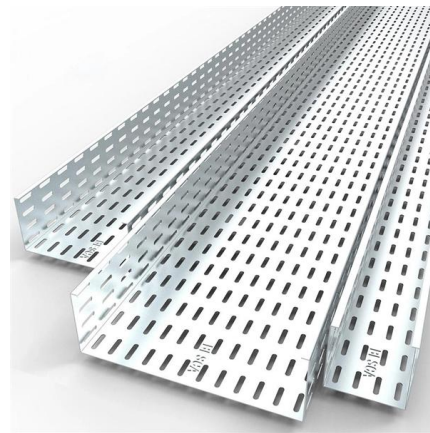

## Trunking and cable tray protection

Our range of trunking and cable tray protection products provide effective fire protection for pipes, cables and trunking within floors, walls and ceilings.

## Fire stop section of the cable tray and cable management NEMA

3MTM+ Fire Barrier CS-195+ Composite Sheets Features & Benefits Ideal for fire-stopping blank openings and through-penetrations of multiple cable, pipe ducts, buss ducts and cable trays



### CABLE TRAY

Armorduct Systems' Cable Tray has achieved a E90 Fire Rating after carrying out testing in accordance with DIN 4102-12 at FIRES notified Technical Assessment Body (TAB), which is managed in



### Fire Resistance Testing of Cable Trays: Key Standards

Fire Resistance Testing of Cable Trays ensures they don't fuel fires or emit toxic smoke. Learn key standards, testing methods, and safety tips.



### Cable tray fire protection solutions

Cable tray fire protection Cable tray fire protection Cable tray fire protection: Go onto any rig, into any petrochemical plant, factory, production plant, hospital, office or





## Benarx Epoxy Cable Tray for passive fire protection

Benarx Epoxy Cable Tray protects critical power and signal cables in case of fire, maintaining their integrity and functionality. The products is known for its

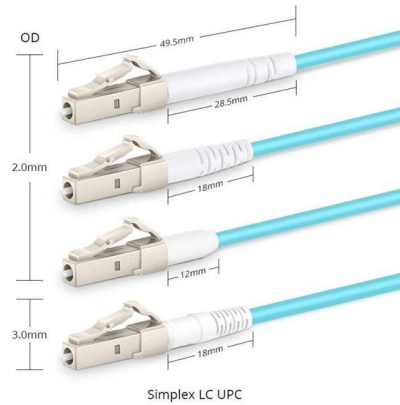

## How do cable trays perform in fire conditions?

To uncover the answer to this question, we have conducted tests on cable tray systems in different materials. Through these tests the aim was to learn more



## Fire Rated Cable Tray

Cable tray designed to offer continuous support of cables Rated load of 12.5kg per metre over a 1.5m Span 1500mm Trapeze Support Spacing Complies with

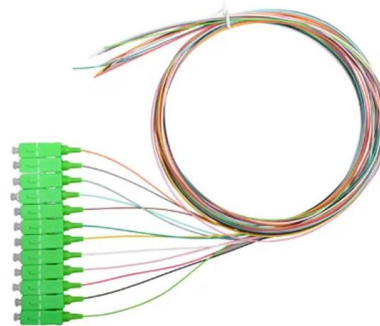

## FIRE RESISTANT SYSTEMS

Cable Tray Gebze IV Istanbul Makine ve Sanayicileri Organize Bolgesi, 6.Cadde, No:2 41455 Demirciler Koyu, Dilovasi - Kocaeli - Turkiye Tel: +90 (262) 999 05 55 Fax: +90 (262) 502 05 70



### Wire mesh, long span cable trays, ladders, support

Interactive PDF - click on the product name and go to the online catalogue! - Cable Trays - Self-supporting Trays - Wire Mesh Trays - Cable Ladders - Long-span

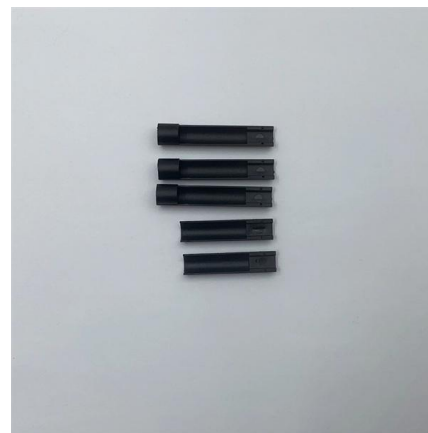

### FIRE RESISTANT PROOF CABLE TRAY, DIN STANDARD E90

Cablofil cable tray is the preferred choice for the cable containment of low and high voltage electric cables where fire resistance is crucial - this includes cable basket tray systems for Prysmian FP



### Cablofil Cable Basket

Cablofil fire resistant and fire proof cable trays are increasingly specified in the construction, power, oil, gas, petrochem, rail and utilities industries. Cablofil cable tray has been successfully tested and



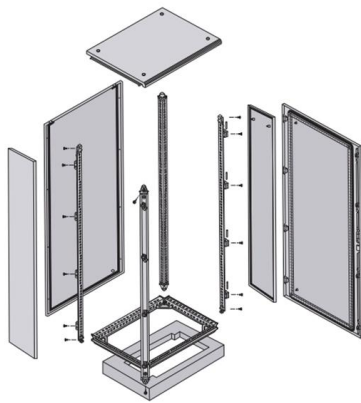

## Fire Rated Cable Support Systems

Fire Rated AS/NZ 3013:2005 Introduction  
Electrical installations are the number one cause of fire in modern buildings in Australia. Fire rated cable support systems can reduce the human cost of fires

## Contact Us

---

For datasheets, pricing, or custom telecom energy solutions, please visit:  
<https://koskolong.co.za>