

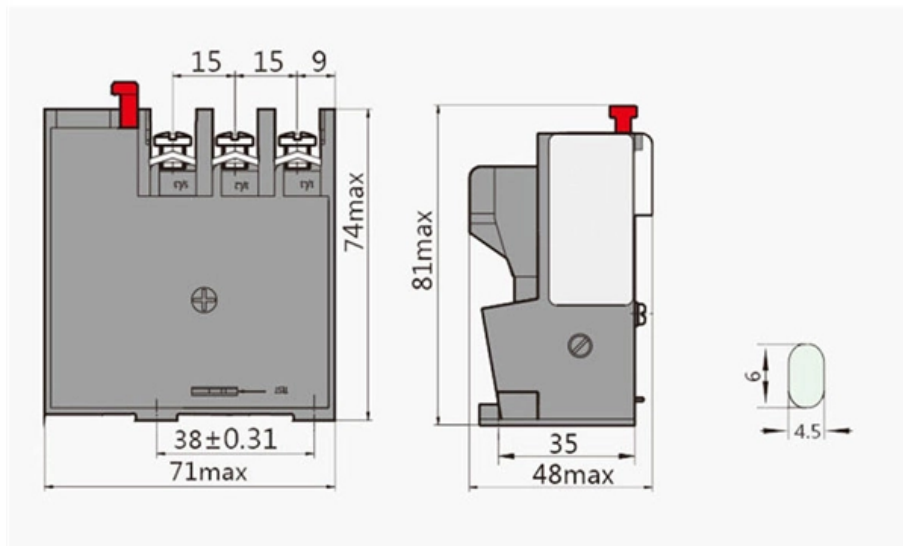

Secondary Equipment Relay Protection Equipment Industry





Overview

This article explores the current trends, innovations, and market insights surrounding relay protection, focusing on tools like the secondary injection test set, three-phase relay test set, and single-phase relay test set. ABB's Control Room offering includes a comprehensive range of solutions designed to optimize the operator workspace for critical 24/7 processes across various industries. IEEE/IAS/I&CPSD Protection & Coordination WG Chair Jacobs Canada, Calgary, AB rasheek. com IEEE Southern Alberta Section PES/IAS Joint Chapter Technical Seminar - November 2016 Protective Relays - Technical Seminar Nov 2016 - Copyright: IEEE 2 Abstract: Protective relays and devices. These clean energy sources, connected through inverters and flexible transmission systems, are transforming traditional grids based on synchronous generators into more flexible and resilient systems. This transition presents significant challenges to system stability. Relay protection systems are essential in maintaining the safety and reliability of modern electrical grids.



widely applied in power utilities and industrial enterprises,

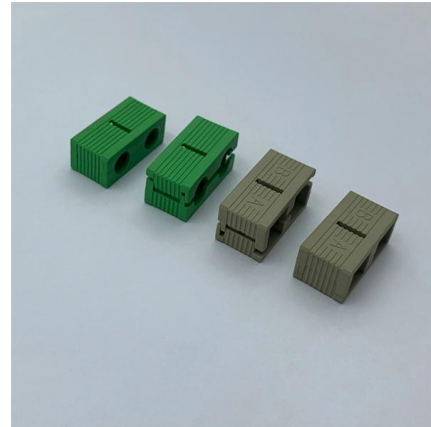

Essential Guide to Protective Relays: Types & Applications

This comprehensive approach to selecting relays will ultimately contribute to the overall effectiveness of a protection scheme. In conclusion, protective relays are indispensable tools in

Power System Protective Relays: Principles & Practices

As the protected components of the electrical systems have changed in size, configuration and their critical roles in the power system supply, some protection aspects need to be revisited (i.e. the use of



Home

P& B introduce the MR-MET131 Directional Relay. P& B is a leading UK innovator of electrical protection, safety and control technologies. Our specialist expertise and unrivalled



Protective Relays for Industrial Electrical Maintenance

This guide explains what protective relays are, how they work, why they matter, and how they integrate with industrial electrical maintenance, transformer services, and emergency electrical



Protective Relay: Working, Types, and Applications

Learn about protective relays, their working principle, types, and applications in power systems. Discover how relays protect transformers,

Secondary Protection Relays

Medium voltage protection and control relays for secondary distribution Protecting and controlling an evolving grid The main purpose of a protection and control relay is to recognize any abnormal power



Power System Protective Relays: Principles & Practices

Abstract: Protective relays and devices have been developed over 100 years ago to provide "last line" of defense for the electrical systems. They are intended to quickly identify a fault and isolate it so the



Auxiliary Relays

Installed in more than 150 countries, our auxiliary relays are the best choice for applications such as safety critical logics in nuclear power plants, galvanic isolation between circuits or interface, contact



PMU-based relays_v2.dvi

Relays detect and locate faults by measuring electrical quantities in the power system which are different during normal and intolerable conditions. The most important role of protective relays is to first

Primary and Secondary Protection Schemes

The Primary relay protection equipment is the first line of defence. The secondary relay scheme comes in line when the primary relay system fails to act. The

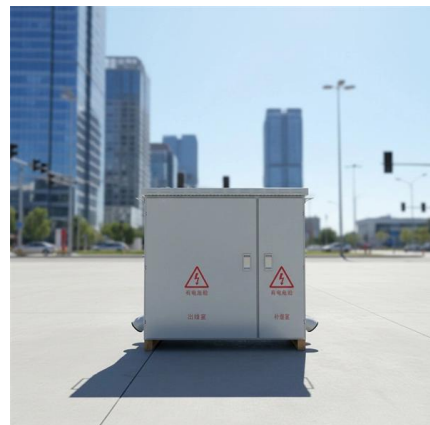



Protection Of Industrial Power Supply Systems (Fuses,

The protection and control of industrial power supply systems must be given careful attention. Many of the techniques that have been evolved for EHV



Centralized Substation Protection and Control

While protection is associated with protecting the power system from abnormal operation, the control system is primarily concerned with supporting the operation of the substation equipment.

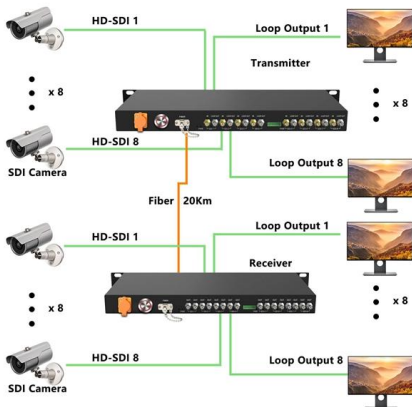
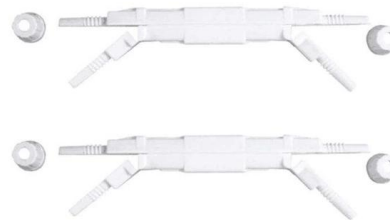

State-of-the-art in the industrial implementation of protective relay

The most important role of protective relays is to first protect individuals, and second to protect equipment. In the second case, their task is to minimize the damage and expense caused by

SPDTableOfContents.qxd

Ground fault protection is equipment protection from the effects of ground faults. The National Electrical Code® (NEC®) has specific ground fault equipment protection requirements in 215.10, 230.95,



What is Protection Relay?

A protection relay is a crucial component of electrical systems that safeguard infrastructure, employees, and equipment from electric problems and

Protective Relay Market Report 2024-2030 [345 Pages]

Protective relays serve an important role in preserving grid stability and dependability by detecting and isolating faults, preventing equipment damage and assuring a

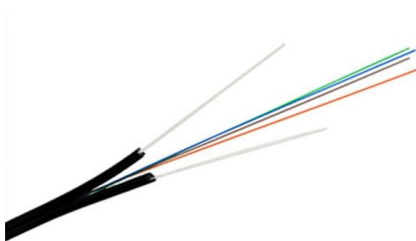

Societal and technology trend report

Next, this framework is applied to two representative line-protection schemes - line distance protection and line differential protection - for quantitative evaluation under PEDG conditions.



Types of Electrical Protection Relays or Protective Relays

? Key learnings: Protective Relay Definition: A protective relay is an automatic device that senses abnormal conditions in electrical circuits and



Unit 2 Secondary Protection Equipment Substations

This document describes the different components and essential equipment found in an electrical substation, including instrument transformers, current and voltage

Secondary Protection Relays

ABB's Relion family of protection and control relays for secondary distribution offers a wide range of products for protection, control, measurement and supervision of power distribution systems for IEC



The Current Situation and Emerging Trends in Relay

This article explores the current trends, innovations, and market insights surrounding relay protection, focusing on tools like the secondary



Protective Relay Market Size, Share & Growth Graph by 2033

The industrial sector dominates the global protective relay market due to its high power consumption and need for reliable electrical protection systems. Industries such as manufacturing, oil



The Current Situation and Emerging Trends in Relay

The relay protection industry has shifted from traditional electromechanical systems to digital relays, supported by advanced testing



Protective Relays

SEL relays detect faults and other abnormal conditions in electric power systems and initiate protective actions to maintain system stability and safety. They are used in a wide range of applications, from





Contact Us

For datasheets, pricing, or custom telecom energy solutions, please visit:
<https://koskolong.co.za>