



Adam Tas Corridor Energy

Specifications and dimensions of factory power distribution boxes





Overview

This list includes substantive updates only and is not intended to reflect all changes.



Specifications and dimensions of factory power distribution boxes



MNS® Low Voltage Distribution Board and Power Cabinet

The ABB-MNS® distribution board and power cabinet are of a welded structure. The product comes in a good variety of shapes, and is highly versatile, structurally innovative, and mechanically rigid. Its

Distribution Boxes

Approximate Dimensions Dimensions are in millimeters (inches). Illustrations are not drawn to scale. chemical resistance 4, 6, or 8 DC micro connectors Screw terminal connection allows for customized



Energy switchgear assembly POWER DISTRIBUTION BOARDS

In order to ensure a reliable power supply, N(PEN) conductors can be designed with the same or higher current-carrying capacity than the phase conductors, especially in networks with a high level of

PowerBox Factory

PowerBox factory offers a vast range of PDUs, distro boxes, racks, panels, adapters, cable extensions and splitters to safely manage power



distribution, all designed



Understanding Power Distribution Boxes: Types, Features, and

This guide delves into the intricacies of power distribution boxes, shedding light on their design, functionality, and regulatory standards. Readers can expect to gain a comprehensive

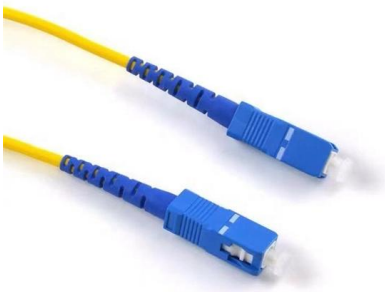

Catalogue 2022

Featuring an ample number of precut, double-size conduit knockouts on all sides to accommodate various industry standard conduit sizes and international standard glands, these knockouts can be

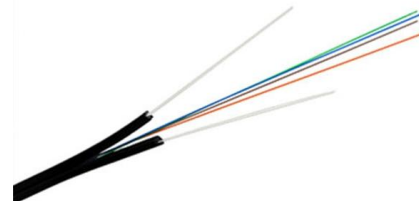

DRAFT SPECIFICATION FOR L. T. DISTRIBUTION BOX OF

1.1. : CONSTRUCTIONAL FEATURES :- L.T. Distribution Box shall be outdoor type and have suitable enclosure (factory built assembly) manufactured by Thermosetting Plastic i.e. Glass Fiber Reinforced



LIEBERT® FPC POWER DISTRIBUTION CABINE

The Liebert FPC power center is engineered to combine the convenience and cost savings of a pre-packaged, factory-tested unit with the flexibility of a custom-tailored power system.

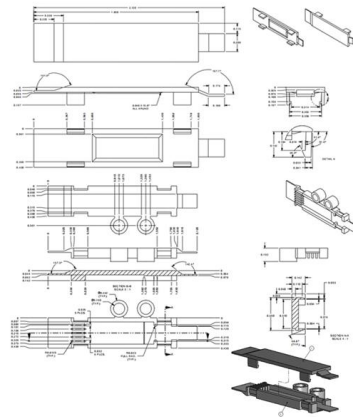

Power Distribution Boxes: A Complete Overview , Eventech

This article covers the types, features, and advantages of power DB boxes, as well as their manufacturers and frequently asked questions.

Power Distribution Equipment

Each has its own unique standards and application guidelines, and one facet of good power system design is the knowledge of when to apply each type of equipment and the limitations of each type of

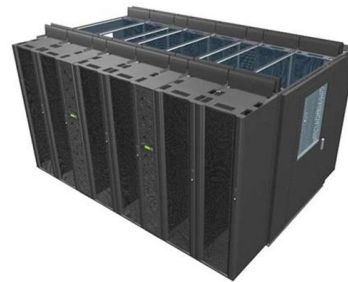

TECHNICAL SPECIFICATION FOR LT DISTRIBUTION BOX

General Technical Particulars for LT Distribution Boxes : - The L.T. Distribution Boxes should be of the dimensions as per the drawing & details in the table furnished.



Electrical Control Panels & Distribution Boxes: Sizes,

Introduction Electrical control panels and distribution boxes are the backbone of modern electrical systems. From powering homes and industrial



Power Distribution Boxes

Custom power distribution boxes featuring precise sheet metal fabrication, designed for efficient power management. Available in various sizes with high-quality

Understanding Distribution Boxes: Your Guide to Power

Weatherproof Distribution Boxes These serve specific outdoor purposes, with rain, dust, and extreme temperatures sealed shut, protecting any





Distribution Boxes Types - The Complete Guide

The power distribution boxes deliver electricity from the main electrical main to other circuits. Several distribution boxes are designed for specific use in

Distribution Boxes: Types and Functions

A distribution boxes acts as the load center and main distributor of electrical power within a building. Also called a distribution board, panel board,



Industrial Plant Distribution Box Layout and Power Distribution

That distribution box in the corner? When designed well, it becomes the invisible backbone letting everything else shine. It's not the most glamorous part of your operation, but get it right, and you'll

Electrical Box Dimensions Manufacture

Large electrical power distribution boxes come in several sizes--single-gang for one device, double-gang for two, and so on. Check out



Distribution Box Guide: Types, Components & Solutions

Understand distribution boxes (DB boxes) in 5 minutes. Learn about types, components, functions, and uses. Find the perfect DB box for your needs.



Complete Guide For Distribution Boxes Types

Distribution boxes, also known as electrical distribution boards or panels, are pivotal components in electrical systems, ensuring the safe and organized distribution of



Distribution Box Specifications And Models

There are many specifications and models of Distribution box. The following are some common specifications and models of distribution boxes and





Power Distribution Box Essentials: Functions, Types

7) Considerations for choosing a power distribution box The context, security needs, and purpose all play a vital role in deciding a power distribution



Power Distribution Boxes Explained Simply

Learn what a power distribution box is, how it works, key components, types, and why it's vital for safe and efficient electrical systems.

Contact Us

For datasheets, pricing, or custom telecom energy solutions, please visit:
<https://koskolong.co.za>