



Adam Tas Corridor Energy

Standard Dimensions of Primary Distribution Boxes in West Asia





Standard Dimensions of Primary Distribution Boxes in West Asia



Design requirements and standards for low voltage

Key Takeaways Always prioritize safety by following NEC and IEC standards for low voltage distribution boxes. Check voltage and current ratings to

Distribution Boxes Types - The Complete Guide

The power distribution boxes deliver electricity from the main electrical main to other circuits. Several distribution boxes are designed for specific use in



e -HANDBOOK on WAREHOUSING STANDARDS

Scope of the e- Handbook This e-Handbook includes the existing standards that are issued by the standards agencies such as the Bureau of Indian Standards (BIS) and the Warehousing

Asia Standard Pallet Fitting Calculator -- How Many Boxes Fit

The calculator is pre-filled with the Asia Standard Pallet 's dimensions and weight rating. Enter



your box dimensions below to see the fitting result and top-down layer diagram.



Distribution box catalogue , PDF

This document provides specifications for various distribution boxes including dimensions, mounting sizes, and number of ways. It includes specifications for

Common Standards for Distribution Boxes in the ASEAN

Distribution boxes are the unsung heroes of electricity networks. They divide power flows, protect equipment, and shield us from surges. But travel across ASEAN and you'll see as many variations as

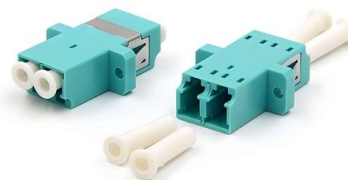

A Definitive Guide To Distribution Boxes

The distribution box acts as the center of power distribution, distributing electricity to all connected devices. A distribution box, also known as a distribution board, panel board, breaker



Distribution box , PDF

This document provides specifications for various types of plastic distribution boxes, including their dimensions and features. It describes HA, HK, and LGD series boxes with dimensions ranging from

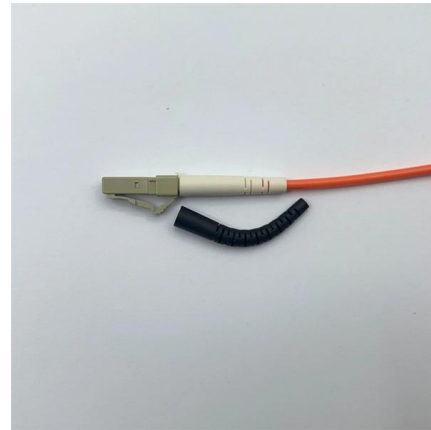

1.An Ultimate Guide for Metal Distribution Boxes

1) Metal Distribution Boxes Constructed from steel, aluminum, or cast iron, metal distribution boxes are highly durable and resistant to mechanical damage. Ideal

Technical Specifications for Distribution Boxes and Switch Boxes

This document sets forth technical, installation and safety specifications for distribution boxes, switch boxes and cabinets. It stipulates requirements for enclosure materials, installation dimensions, the



Logistikrichtlinie

"Regional Packaging Guideline" is the basic regulation for oversea suppliers as well as domestic suppliers who are being nominated to supply components to Asian plants (joint ventures included).



Understanding Distribution Boxes:A Comprehensive Guide

Understanding its significance, this article covers what a distribution box is, how it functions, its structure, the various types available, and how it

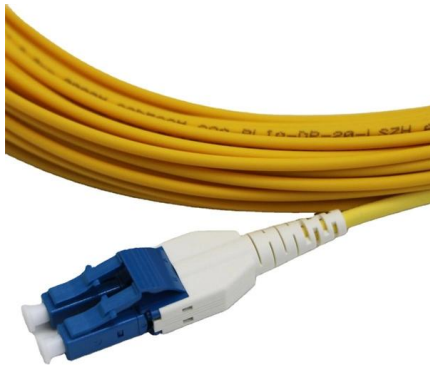

The pallet standards minefield

In Australia, the most common pallet size is the ISO-approved 1165mm x 1165mm. Within Asia, the two most popular pallet sizes are the square

Comprehensive Guide to Septic Distribution Box Dimensions

Conversely, an oversized box may not distribute the effluent evenly, leading to uneven saturation of the drain field and potential system failure. In this guide, we will delve into the various





The Meaning and Function of Primary, Secondary, and Tertiary

Follows the principle of "one machine, one switch, one RCD, one box, one lock," ensuring no single switch controls multiple devices. This explanation aims to clarify the roles and functions of



Final Power Distribution Boxes , Product Catalog , CHINT Global

Compact final distribution boxes for safe, accessible, and precise power control across all electrical environments.



Cautions and Requirements for Installation of

When the distribution box is installed and constructed, some safety operation items have become the primary premise of the work. Therefore, there are certain

Area distribution boxes with connectors

The area distribution box associated with the copper or optical feedthrough sockets allows total flexibility: the connections close to the workstation are centralised.



Requirements And Specifications For Installation Of

In flammable and explosive environments, explosion-proof distribution boxes should be selected and explosion-proof treatment should be carried out.

TECHNICAL SPECIFICATION I.R.O. 63,100,160 & 315 KVA

Distribution Boxes shall have Isolator (Switch Disconnecter) on incoming circuit and Porcelain CUTOUT fuse base disconnecter on outgoing circuits with necessary interconnecting Bus Bars.



e -HANDBOOK on WAREHOUSING STANDARDS

This e-Handbook includes the existing standards that are issued by standards agencies such as the Bureau of Indian Standards (BIS) and the Warehousing Development and Regulatory Authority



Distribution Board

The Distribution Board, refers to an equipment which consists of bus bars, and possible switches, fuse links and Automatic protective equipment, bypass equipment, for connecting, controlling and

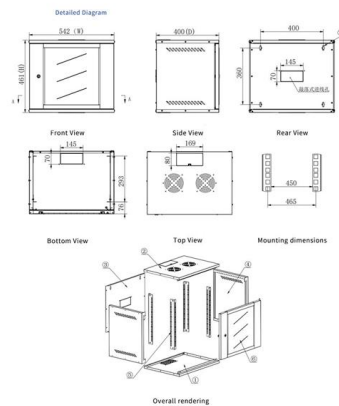

Distribution Box

Metal Distribution Box Features Continuously welded seams Foam-in-place seamless gasket 120-degree opening heavy-duty industrial hinges IP66 protection rating against dust and water according



Distribution Box Guide: Types, Components & Solutions

Understand distribution boxes (DB boxes) in 5 minutes. Learn about types, components, functions, and uses. Find the perfect DB box for your needs.



How to choose a distribution box of the right size for a project based

If you're like most electrical professionals, picking the right distribution box for your project can feel like navigating a maze. I've been in those shoes - staring at spec sheets, worrying about

Distribution Boxes: Types and Functions

Learn what an electrical distribution box (DB/distribution board) is, its main components (MCB/RCCB/RCBO, SPD, busbar) and common types.



How to determine the size, installation method and

9) The wood brick and iron parts needed for the installation of the distribution board need to be buried in advance, and the exposed distribution box should be fixed





Contact Us

For datasheets, pricing, or custom telecom energy solutions, please visit:
<https://koskolong.co.za>