



Adam Tas Corridor Energy

The most commonly used light source in fiber optic communication measurement





Overview

The workhorse behind modern telecommunications is infrared light , specifically with wavelengths between 1310 nm and 1550 nm . This isn't an arbitrary choice; it's a calculated engineering decision driven by the physics of silica glass. In practical systems, these light sources are almost always semiconductor diode lasers or LEDs. The most important elements of optical communication are a transmission medium with extremely low optical attenuation and a highly stable, long-life light source that operates with a small current. It is commonly used together with optical power meters to measure insertion loss, verify link performance, and ensure compliance with industry standards across telecom networks, data centers, and FTTH deployments. What you will learn from this guide: □□ What Is a Fiber Optical Light Source?

A fiber.



The most commonly used light source in fiber optic communication



Fiber Optic Light Sources Explained

Light emitting diodes (LEDs) and laser diodes are commonly used light sources in fiber optic communication systems. LEDs have lower power output and speed

All Kinds of Fiber Optic Patch Cords - SC, LC, FC, ST

Learn about SC, LC, FC, and ST fiber optic patch cords, their uses in FTTH, telecom, and data centers, and how to choose the right type.

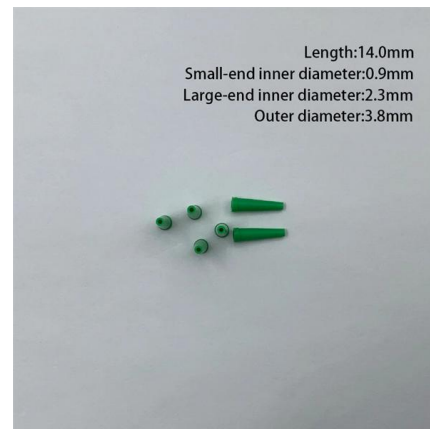

Laser

Lasers are used in fiber-optic and free-space optical communications, optical disc drives, laser printers, barcode scanners, semiconductor chip manufacturing

Two Primary Types of Light Sources in Optical Fiber

Each type of light source has distinct characteristics, performance attributes, and



applications based on their principles of operation, light emission,



LIGHT SOURCES

For most fiber optic sensors, semiconductor-based light sources offer advantages in power consumption, reliability, size, and cost that often preclude the selection of alternative light sources.



Scattering

A wine glass in an LCD projector's light beam makes the beam scatter. In physics, scattering is a wide range of physical processes where moving particles or

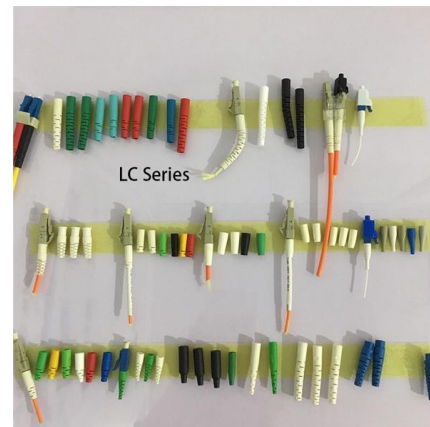

Broadband Light Sources For Optical Fiber Communication

Broadband light sources are frequently replaced by lasers, which produce a coherent and almost monochromatic output. In this blog, we will look at



Broadband Light Sources For Optical Fiber Communication

The tungsten-halogen lamp, which is normally driven by a stable DC power supply, is the most popular broadband light source used for near-IR



Basic Operation and Types of LED Light Sources Used

Surface Emitting LEDs (SELEDs) are the most common type of LED used in fiber optic communication systems. These LEDs emit light from their

Single Mode vs Multimode Fiber, What is The

Learn the key differences between single mode vs multimode fiber cables and choose the right one for your fiber optic system.



Security alarm

A fiber-optic cable can be used to detect intruders by measuring the difference in the amount of light sent through the fiber core. A variety of fiber optic sensing



Light Sources in Fiber Optic Technology

Fiber-optic communication systems require a light source to generate the signal that the fiber transmits. In practical systems, these light sources are almost always semiconductor diode lasers or LEDs.



Which type of light is used in optical fiber

Optical fiber primarily uses infrared light, not visible light, due to lower signal attenuation. Common wavelengths are 1310nm and 1550nm, where silica glass

Light Sources for Optical Communication

Analysis of Light Sources for Optical Communication The choice of light source depends on the specific application and the required performance metrics. For example, for short-haul





Wireless

Wireless communication (or just wireless, when the context allows) is the transfer of information (telecommunication) between two or more points without the use of

Light Sources in Fiber Optic Technology

Fiber-optic communication systems require a light source to generate the signal that the fiber transmits. In practical systems, these light sources are almost always semiconductor diode lasers or LEDs.

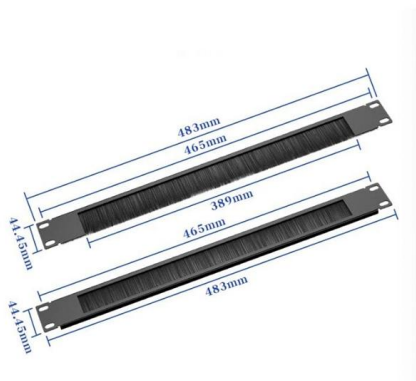

Fiber Optic Light Sources Explained , PDF , Light

Light emitting diodes (LEDs) and laser diodes are commonly used light sources in fiber optic communication systems. LEDs have lower power output and speed

Light Sources in optical fiber communication , PPT

Light sources are devices that generate the optical signals transmitted through fiber optic cables. In fiber communication, the most commonly used light sources are



Low Fiber Optic Coupler Price

A fiber optic coupler is a passive optical device used to split, combine, or distribute light signals in fiber optic networks. The price of a fiber optic coupler varies significantly based on its type, functionality,



Optical Sources and Detectors , part of Fiber Optic and Atmospheric

The most common photodetector for optical communications (fiber and wireless) is the semiconductor junction photodiode, which converts optical power to an electric current.



Fiber Optical Light Source: Definition, Types and Uses

This is where a fiber optic light source plays a key role. It is commonly used together with optical power meters to measure insertion loss, verify link performance, and ensure compliance with



12 core multi mode fiber optic cable

About 12 core multi mode fiber optic cable Types of 12-Core Multimode Fiber Optic Cables A 12-core multimode fiber optic cable is a widely used solution in modern networking infrastructure, offering



Single Mode vs. Multimode Fiber Optic Cables

There are two main types of fiber optic cables: single mode and multimode. Although they can do the same job in some instances, the different

Wiley Online Library , Scientific research articles, journals, books

Hier sollte eine Beschreibung angezeigt werden, diese Seite lässt dies jedoch nicht zu.

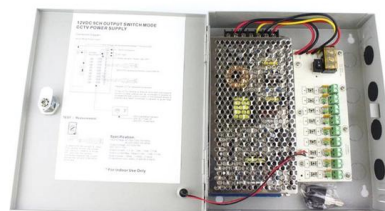

Optical Fiber Communications 101: Key Concepts

The light used in optical fiber communication is not natural light like sunlight, but artificially created light like lasers. Figure 13 shows examples of optical spectra of

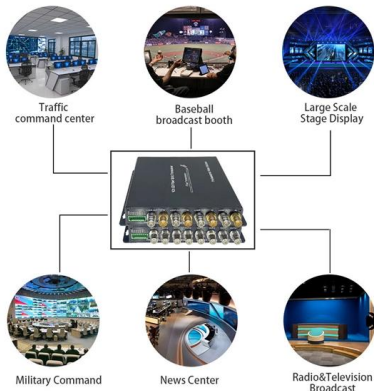

List of laser types

List of laser types An immense slab of "continuous melt" processed neodymium -doped laser glass for use on the National Ignition Facility. This is a list of laser types, their operational wavelengths, and



Fluorescence

Fluorescence occurs when a photon from incoming radiation is absorbed by a molecule, exciting it to a higher energy level, followed by the emission of light as

WORLD WIDE WEB JOURNAL Home

O'Reilly & Associates, Inc. 103A Morris St. Sebastopol, CA United States





Laser Sources for Fiber Optics: Understanding Their Role in Data

Explore the essential role of laser sources in fiber optic communications. Understand how different types of lasers, such as semiconductor, fiber, and solid-state lasers, contribute to high

Contact Us

For datasheets, pricing, or custom telecom energy solutions, please visit:
<https://koskolong.co.za>