



Adam Tas Corridor Energy

U-shaped cable tray production





Overview

This comprehensive guide provides a detailed overview of cable tray making machine technology, working principles, types of machines available, manufacturing process, raw materials required, applications where used, cost considerations, tips for choosing suppliers . One of the main advantages of U-shaped cable tray roll forming machines is their ability to produce consistent and accurate results. The machine is equipped with precision engineering and high-quality components to ensure that each cable tray meets the required specifications. The cable tray production line is an intelligent mechanical integrated system designed for the production of cable tray systems, which realizes the precise forming of the bridge structure through automated processes. Cable tray manufacturing relies on a coordinated production line of specialized machines: a roll forming line shapes the profile, a CNC press brake handles secondary bending, a punch press creates mounting holes and ventilation slots, and a shearing line cuts the finished tray to length. Roll Forming Machine, Roof Roll Forming Machine, PU Sandwich Panel Line, CZ Purlin Roll Forming Machine, Deck Floor Roll Forming Machine, Stud Roll Forming Machine, Glazed Tile Roll Forming Machine, Cold Roll Forming Machine, Dry Wall Roll Forming Machine, Slitting Line Basic Info.



U-shaped cable tray production



Cable Tray Making Machine

Cable tray making machines are used to manufacture cable trays - an important component in electrical installations and industrial buildings for routing cables and wires safely. This

U-LI Steel Cable Tray Catalogue

The document describes United U-LI Steel Surface Cable Tray and Accessories. It provides details on the product range which includes perforated tray series for



Comprehensive Guide to Cable Tray Production Line Systems and

A robust and reliable cable tray production line is crucial for meeting this demand. This article will delve into the intricacies of these production lines, examining the key components,

CABLE TRAY

Cable Support Systems are well designed to provide necessary support for cable trays, cable ladders and trunkings. Cable supports are



manufactured according to common standards from high quality



Cable Tray

Manufacturer of Cable Tray - Perforated Cable Trays, Ladder Type Cable Trays, Galvanized Cable Trays and Gi Cable Tray offered by U- Protec Earthing Private



Cable Tray Production Line , Cable Tray Roll Forming

We customize according to customer requirements and meet your semi-automatic or fully automated processing requirements. Please follow us to learn about the

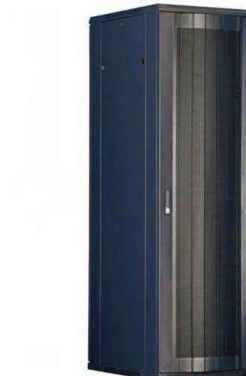

Cable Tray Production Line

Description cable tray making machines,cable tray roll forming machine,Cable Tray Production Line from Wuxi JSR machinery factory make different sizes of cable





Advanced Applications of Ladder Cable Trays in

Introduction As Indonesia accelerates its digital transformation and industrial growth, advanced cable management systems have become critical



Technical Data Sheet Cable Tray System

The cable trays are manufactured from Pre-galvanized steel conforming to BS EN 10346:2009, and consist of both a Medium duty and Light Duty product range. our high integrity wrap over couplers.

U Shaped Cable Tray Industry Roller Forming Machine

U Shaped Cable Tray Industry Roller Forming Machine, Find Details and Price about Cable Ladder Roll Forming Machine Cable Tray Roll Forming Machine from U Shaped Cable Tray Industry Roller



U shape cable tray

Discover high-quality u shape cable tray designed for efficient cable management, offering durability and easy installation. Ideal for enhancing organizational systems in commercial settings.



Cable Tray Production Line

All cable trays and their covers are produced in the roll forming line which is consisting of the decoiler, straightener, feeder, roll forming machine, punching unit, cutting machine and the stacking unit. What



U shape cable tray bracket

Find high-quality u shape cable tray brackets for secure and efficient cable management. Shop our range of durable, zinc-plated steel supports for various applications.

cable tray production line

Our advanced cable tray production line is engineered to provide automated forming, punching, and cutting processes for various types of cable trays, including

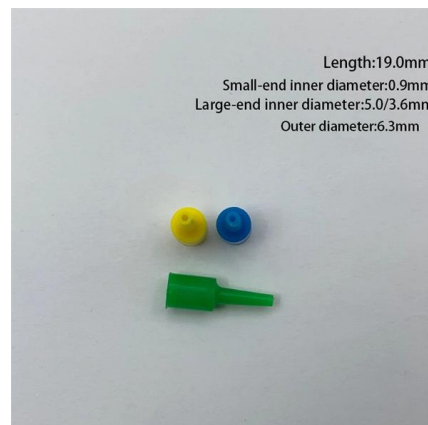



Cable Tray Making Machine

These versatile CNC operated machines produce all types of cable trays like ladder type, solid/ventilated channel types, center spine designs etc. in one production line.



Cable Tray Production Line , Cable Tray Roll Forming

The cable tray production line is an intelligent mechanical integrated system designed for the production of cable tray systems, which realizes the precise



Cable Tray Roll Forming Machine, Cable Tray

The roll forming production line is the most widely used method for manufacturing cable trays. It supports multiple production batches and offers large-scale



Comprehensive Guide to Cable Tray Production Equipment

Explore the ultimate guide to cable tray production equipment. Learn about types, features, and trends to improve efficiency, precision, and



U-shaped steel cable tray features

U-shaped steel cable tray is the most widely used steel cable tray in China, which is common indoors and outdoors, and has excellent load bearing capacity, which is suitable for large



Cable Tray Roll Forming Machine: The Ultimate 2025 Guide

Overview of Cable Tray Roll Forming Machines A Cable Tray Roll Forming Machine is a specialized piece of industrial equipment designed to manufacture cable trays from metal coils. The

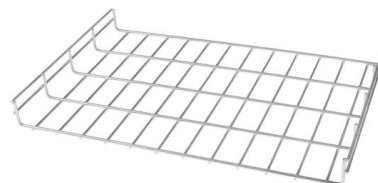

Cable Tray Roll Forming Machine

According to production needs, cable tray with strip steel width of $100\text{mm} \leq \xi \leq 860\text{mm}$ can be rolled. Production speed during online punching: 2.5-5



Cable Tray Manufacturing Machines: Press Brake, Punch Press

Learn which machines make cable trays -- roll forming, press brake, punch press, and shearing line. Step-by-step process guide, specifications, and machine selection tips for 2026.

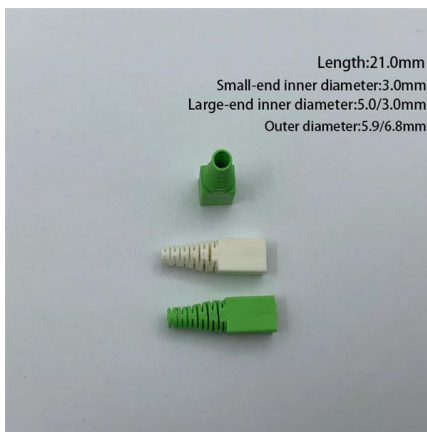
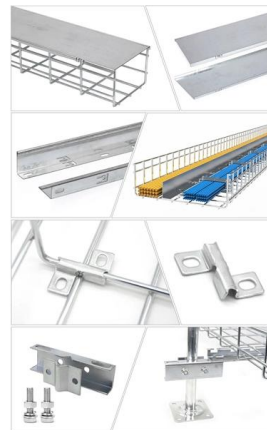

CPI Cable Pathway Solutions White Paper 34811

As expected, the presence of OnTrac Shaped Tray's flattened wires produced more surface area and support than round cross wires. Further illuminated through testing and side-by-side comparisons,

How to Produce Cable Trays: A Comprehensive Guide

Discover the detailed process on how to produce cable trays, covering everything from material selection to assembly and surface treatment.



U purline cable tray roll forming machine

The machine is equipped with precision engineering and high-quality components to ensure that each cable tray meets the required specifications. This not only



PVC-U Cable Tray

PVC-U Cable Tray Systems Flat 90° bends
 Ordering Code Width Depth Ordering Code Width
 Depth mm mm mm mm CPF075050 75 50
 CPF0200075 200 75 CPF0100050 100 50
 CPF0300075 300

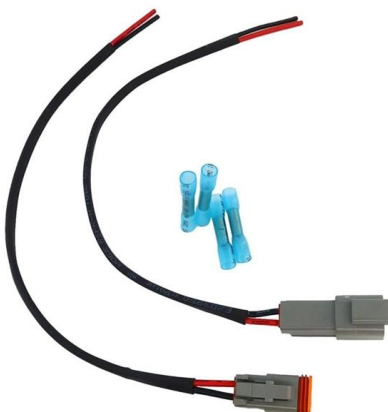

Mild Steel U Shape Perforated Cable Tray

Conclusion Mild steel U-shape perforated cable trays are a reliable and practical choice for cable management. Their strength, affordability, and ease of use make



High Quality U Shape Cable Tray Production Line

High Quality U Shape Cable Tray Production Line
- Cindy zeng -whatsapp/wechat :+86
18600753768 LI 202 subscribers Subscribe

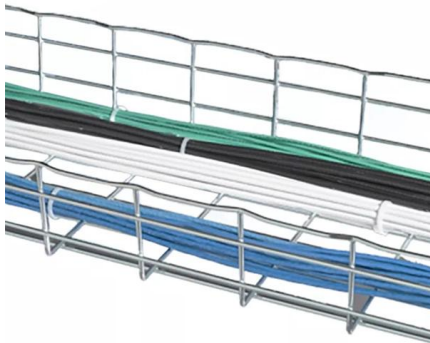
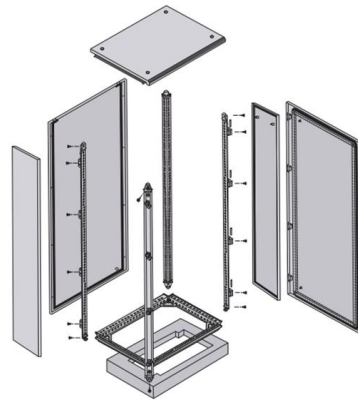

Wire Mesh Cable Tray Solutions o PFLITSCH

A coordinated range of accessories with hygiene-optimised fastening solutions and roof-shaped covers further adds to the exceptional hygienic design of this cable trunking system. However, our Wire-tray

Contact Us

For datasheets, pricing, or custom telecom energy solutions, please visit:
<https://koskolong.co.za>