

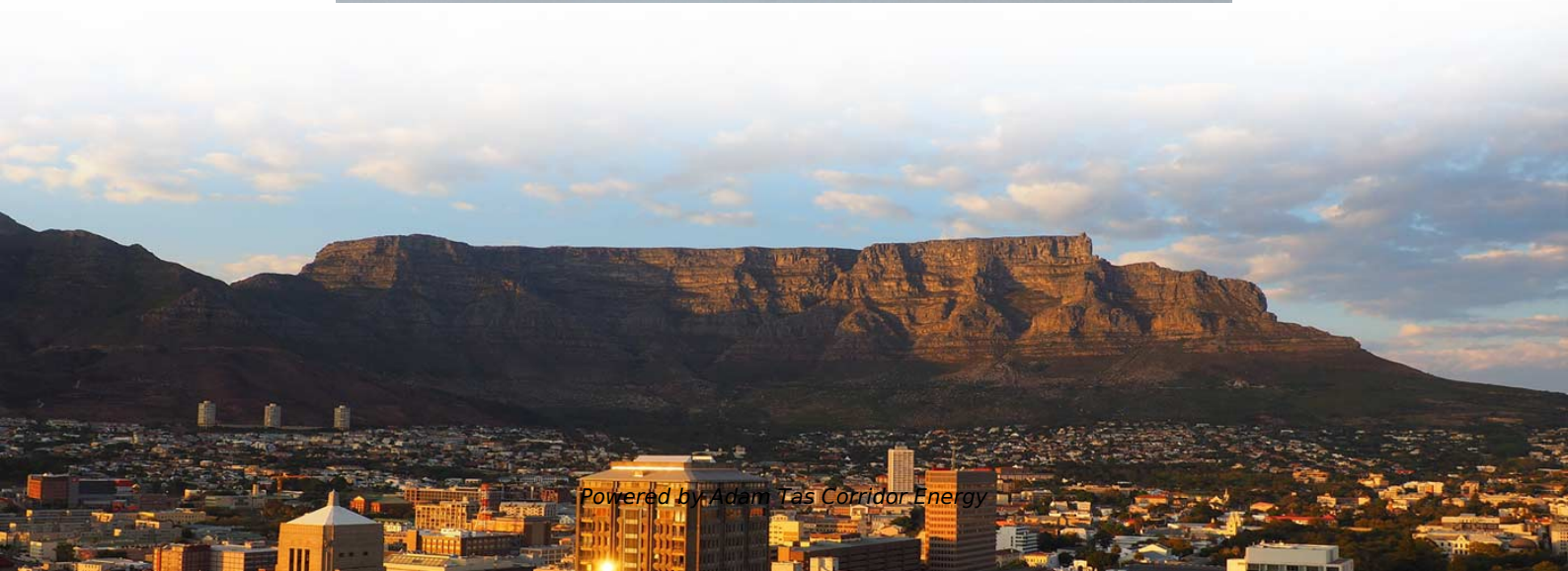

**Adam Tas Corridor Energy**

# **Working principle diagram of integrated beam splitter**





## Working principle diagram of integrated beam splitter

---

### Beam Splitter

A beam splitter is defined as an optical device that effects a linear transformation of fields presented at two input ports, producing output beams that are related to the input fields in a characteristic manner



### MMI-based Polarization Beam Splitter/Combiner for InP

An MMI-based polarization splitter/combiner with a TE-TM splitting ratio above 15 dB over a 21 nm wavelength range is demonstrated. The compact



### Beam splitters

Advanced research often explores specialized beam splitters for use in cutting-edge applications like laser systems, quantum optics, interferometry, and imaging systems. There's significant focus on

### Beam Splitters: Explained

1x5 diffractive beam splitter The working principles of a diffractive beam splitter are similar to diffraction grating. In the case of DOE



however, the

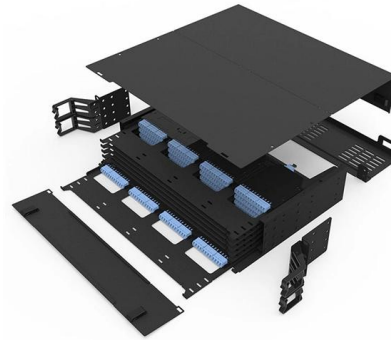

### Optical Beam Splitters: Examination of Designs and Applications in

Explore the essential role of optical beam splitters in various fields, including telecommunications, laser systems, and medical devices. Learn about different types of beam splitters, such as plate, cube, and



### What is a Beam Splitter, and What are Its Functions and

Definition and Working Principle A beam splitter is an optical device designed to split an incident light beam into two or more separate beams. It



### a) Schematic diagram of the working principle of the polarization beam

Here, this work demonstrates an effective strategy to design a multifunctional polarization controller through the integration of frequency and angular multiplexing.



## Transmission and Reflection by Beamsplitters

Transmission and Reflection by Beamsplitters - Java Tutorial A beamsplitter is a common optical component that partially transmits and partially reflects an

Length:14.5mm  
Small-end inner diameter:2.0mm  
Large-end inner diameter:3.5mm  
Outer diameter:5.2mm



## Fiber-optic splitter

Fiber-optic splitter A fiber-optic splitter, also known as a beam splitter, is based on a quartz substrate of an integrated waveguide optical power distribution device, similar to a coaxial cable transmission

## What are Beamsplitters?

Cube beamsplitters are constructed using two typically right angle prisms (Figure 1). The hypotenuse surface of one prism is coated, and the two prisms are cemented



## Fiber Optic Splitter Working Principle: An Overview

The working principle of fiber splitters involves the redistribution of optical power between the output fibers, ensuring an equal division of the signal



## Optical Splitters Demystified: The Silent Heroes

? How Does an Optical Splitter Work? The working principle is based on the fundamental physics of light. Light, traveling through the core of a fiber



## How Does a Beamsplitter Work? , Cube vs. Plate Comparisons

Technical guide on beamsplitter working principles. Compare plate, cube, and polka-dot designs for laser and interferometry systems.

## Methods and applications of on-chip beam splitting: A

The construction of large-scale integrated photonic circuit cannot be separated from the important role played by silicon-based optoelectronic devices.

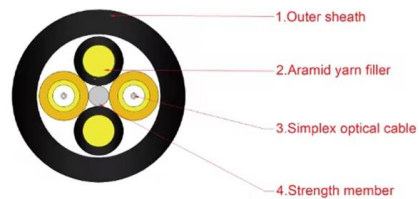



## Understanding Beamsplitters: A Comprehensive Guide

Beamsplitters play a critical role in a variety of optical applications, splitting or combining beams. They are used in microscopy, laser systems, and

## Flyriver: Understanding the Beam Splitter: Principles, Applications

The beam splitter is a fundamental optical component used to divide a beam of light into two or more separate beams. This seemingly simple device plays a crucial role in a wide variety of scientific and



## Beamsplitters Guide: Principles, Types, and Applications

Beamsplitters play a central role in laser applications due to the low absorption and ability to separate a single laser beam into multiple individual

## Working Principle Of Optical Splitter

Optical splitter is a core passive device in FTTH system. Optical splitter, also called optical beam splitter, is an integrated waveguide optical power



## How Beam Splitters Work

The theory behind how a beam splitter works can be used to model quantum frequency transduction, even when the transduction process does not actually

## How Beamsplitters Work: Principles and Applications

Beamsplitters are fundamental components in optical engineering, serving to precisely divide a single input beam of light into two distinct output beams. This division allows for the



## Beam Splitters in Electromagnetism

Discover the role of beam splitters in electromagnetism and optics, including their types, working principles, and uses in various scientific and industrial applications.





## How Beamsplitters Work: Types, Mechanisms, and

Beamsplitters are optical devices able to either split an incident light beam into two separate beams or combine two incoming beams from distinct



## Understanding Fiber Optic Splitters: Principles,

The working principle of fiber optic splitters is based on the 1:N splitting principle. This principle allows a single input light beam to be split into N output light beams.

## How does a beam splitter work? Common types and use cases

Beam splitters are essential optical components used to divide a beam of light into two or more separate beams. They play a crucial role in various scientific, industrial, and everyday

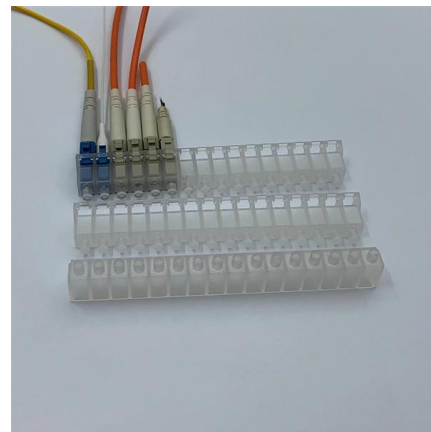

## Beam Splitters - optical power splitter, beamsplitter, thin-film

Beam splitters are devices for splitting a laser beam into two or more beams. There are different types, including polarizing and non-polarizing versions.



## What is a Beam Splitter?

Non-polarizing beam splitter cubes can be made by refining the design, normally via a multilayer coating between the prisms. The substantial angle of incidence will naturally introduce a

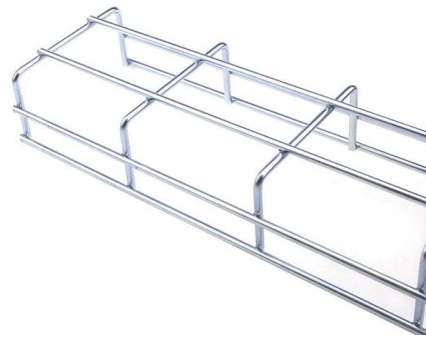

## Understanding Beamsplitters: Types, Principles, and

Beamsplitters can differ in size, shape, and material, but the working principle remains the same: the splitter transmits one part while reflecting the other.

## Contact Us

---

For datasheets, pricing, or custom telecom energy solutions, please visit:  
<https://koskolong.co.za>